

freud

IZAR  
CUTTING TOOLS

2023

# KATALOG

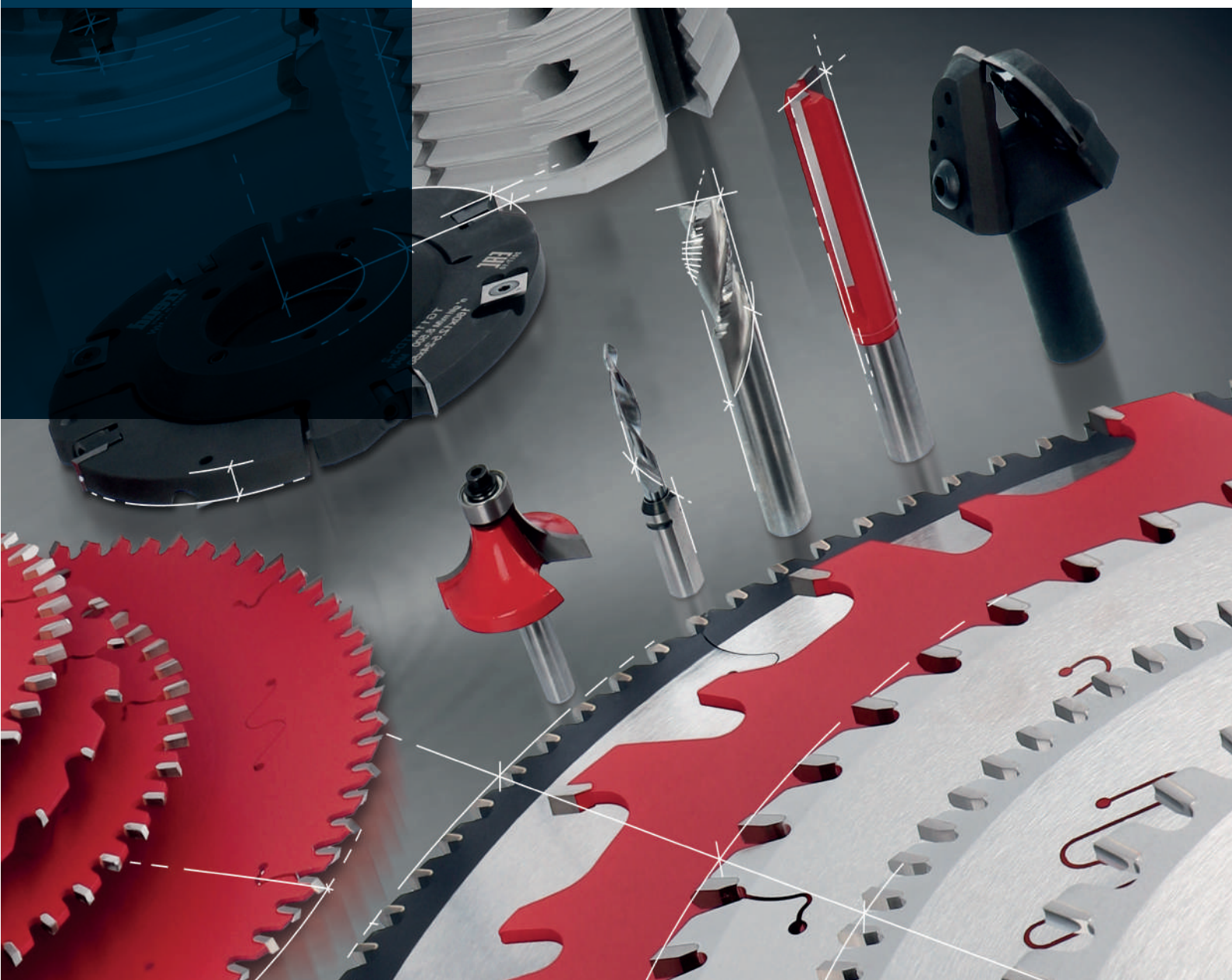

 everest





**freud**

## SUNTALAM & MDFLAM TESTERELERİ TRAPEZ DİŞ

freud

Çizici testere ile çift lamine panelleri yüksek yüzey kalitesi ve uzun kesme ömrü ile detaylı melamin kaplamalı panelleri ölçülendirmek için.

**Makineler:**  
Yatar makineler, yatay panel ebatlama makineleri  
**Özellikler:**  
Pozitif kesme açısına sahip trapez diş

**Malzeme:**  
Çift lamine paneller

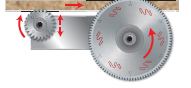

D mm	B mm	b mm	d mm	Z	a°	NL	MAKİNE/AÇIKLAMA	ÜRÜN KODU	FİYAT
200	3.2	2.2	30	64	5°	2/7/42	STANDART YATAR	LU3D 0100	2.979,00
220	3.3	2.2	20	64	5°	2/7/42	STANDART YATAR	LU3D 0201	3.686,00
250	3.2	2.2	30	80	5°	FT01	STANDART YATAR	LU3D 0400	3.372,00
300	3.2	2.2	30	96	5°	FT01	STANDART YATAR	LU3D 0600	4.236,00
350	3.5	2.5	30	72	10°	FT02	STANDART YATAR	LU3D 2000	4.790,00
350	3.5	2.5	30	108	5°	FT02	STANDART YATAR	LU3D 0900	5.450,00

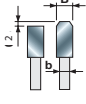

## SUNTALAM & MDFLAM TESTERELERİ TRAPEZ DİŞ TEFLON KAPLAMA

freud

Çizici testere ile çift lamine panelleri yüksek yüzey kalitesi ve uzun kesme ömrü ile detaylı melamin kaplamalı panelleri ölçülendirmek için.

**Makineler:**  
Yatar makineler, yatay panel ebatlama makineleri  
**Özellikler:**  
Pozitif kesme açısına sahip trapez diş

**Malzeme:**  
Çift lamine paneller

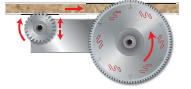

D mm	B mm	b mm	d mm	Z	a°	NL	MAKİNE/AÇIKLAMA	ÜRÜN KODU	FİYAT
250	3.2	2.2	30	80	5°	FT01	STANDART YATAR	LA92MT 003	3.091,00
300	3.2	2.2	30	96	5°	FT01	STANDART YATAR	LA92MT 001	3.719,00



## SUNTALAM & MDFLAM TESTERELERİ SIVRI DİŞ

freud

Çift lamine panelleri bir çizici testere kullanmadan her iki tarafa mükemmel yüzey kalitesi ile ölçülendirmek için.

**Makineler:**  
Yatar makineler, dikey panel ebatlama makineleri, taşınabilir makineler  
**Özellikler:**  
ATB 38° diş

**Malzeme:**  
Aşırı hassas kaplamalar, cilalı panellere sahip çift lamine paneller



D mm	B mm	b mm	d mm	Z	a°	NL	MAKİNE/AÇIKLAMA	ÜRÜN KODU	FİYAT
250	3.2	2.2	30	80	-2°	FT01	STANDART YATAR	LU3A 0200	3.671,00
300	3.2	2.2	30	96	2°	FT01	STANDART YATAR	LU3A 0300	4.467,00



## OLUKLU TESTERE

Çizici testere kullanılmadan çift lamine panelleri yüksek yüzey kalitesi ve uzun kesme ömrü ile ölçülendirmek için.

**Makineler:**  
Daire testere, çizici testere olmayan yatay ve dikey makineler  
**Özellikler:**  
Negatif kesme açısına sahip oluklu diş

**Malzeme:**  
Yapışkan ve sert kaplamalara sahip çift lamine paneller



D mm	B mm	b mm	d mm	Z	a°	NL	MAKİNE/AÇIKLAMA	ÜRÜN KODU	FİYAT
303	3.2	2.2	30	60	-5°	FT01	STANDART YATAR	LU3C 0300	5.192,00

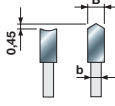

## TEKLI ÇİZİCİLER

Çift lamineli panellerde kaplamayı çizmek için.

**Makineler:**  
Yatar makineler

**Malzeme:**  
Çift lamine paneller



D mm	B mm	b mm	d mm	Z	a°	MAKİNE/AÇIKLAMA	ÜRÜN KODU	FİYAT
120	2.8-4.0	2.2	20	24	0°	STANDART YATAR	LI25M28 EA3	2.010,00
125	3.1-4.3	2.2	20	24	0°	STANDART YATAR	LI25M31 FA3	1.868,00
150	3.1-4.3	2.2	30	36	8°	SCM	LI25M31 KC3	2.894,00
180	3.4-4.6	2.2	25.4	36	8°	TÖRK	LI25M34 NN3	5.342,00

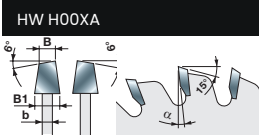

## ÇİFTLİ ÇİZİCİLER

Çift lamineli panellerde kaplamayı çizmek için.

**Makineler:**  
Yatar makineler

**Malzeme:**  
Çift lamine suntalam veya mdflam



D mm	B mm	d mm	Z	a°	MAKİNE/AÇIKLAMA	ÜRÜN KODU	FİYAT
100	2.8-3.6	20	12+12	11°	MARTİN-SHELLING	LI16M BA3	3.671,00
125	2.8-3.6	20	12+12	11°	STANDART YATAR	LI16M FA3	3.671,00

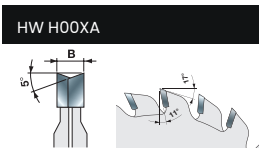

## ATLAMALI AĞAÇ TESTERELERİ (SEYREK DİŞ)

Dilimleme için uygun testereler.

**Makineler:**  
Yatar makineler, çoklu dilme makineleri  
**Özellikler:**  
ATB 10° diş, pozitif kesme açılı

**Malzeme:**  
Yumuşak ve sert ağaç, ayrıca gevşek budaklı



D mm	B mm	b mm	d mm	Z	a°	NL	MAKİNE/AÇIKLAMA	ÜRÜN KODU	FİYAT
250	3.2	2.2	30	22	20°	FT01	STANDART YATAR	LU1C 0100	1.770,00
300	3.2	2.2	30	26	20°	FT01	STANDART YATAR	LU1C 0400	2.150,00
350	3.5	2.5	30	30	20°	2/10/60	STANDART YATAR	LU1C 1000	3.410,00
400	4.0	2.8	30	34	20°	2/10/60	STANDART YATAR	LU1C 1300	4.180,00



## AĞAÇ TESTERELERİ

Boyuna ve enine kesim için uygun testereler

**Makineler:**  
Yatar makineler, taşınabilir makineler  
**Özellikler:**  
Pozitif kesme açısına sahip ATB diş

**Malzeme:**  
Yumuşak ve sert ağaç, işlenmemiş sunta-  
lam ve kontrplak

D mm	B mm	b mm	d mm	Z	a°	NL	MAKİNE/AÇIKLAMA	ÜRÜN KODU	FİYAT
150	3.2	2.2	30	48	5°	2/7/42	STANDART YATAR	LU2C 0100	2.013,00
180	3.2	2.2	30	56	5°	2/7/42	STANDART YATAR	LU2C 0400	2.305,00
250	3.2	2.2	30	48	10°	FT01	STANDART YATAR	LU2B 0500	2.551,00
250	3.2	2.2	30	60	10°	FT01	STANDART YATAR	LU2B 0700	2.800,00
250	3.2	2.2	30	80	5°	FT01	STANDART YATAR	LU2C 1200	3.384,00
300	3.2	2.2	30	48	15°	FT01	STANDART YATAR	LU2A 2100	2.898,00
300	3.2	2.2	30	60	10°	FT01	STANDART YATAR	LU2B 0900	3.186,00
300	3.2	2.2	30	72	10°	FT01	STANDART YATAR	LU2B 1100	3.429,00
300	3.2	2.2	30	96	5°	FT01	STANDART YATAR	LU2C 1500	4.009,00
350	3.5	2.5	30	54	15°	FT02	STANDART YATAR	LU2A 2800	3.970,00
350	3.5	2.5	30	72	10°	FT02	STANDART YATAR	LU2B 1400	4.459,00
350	3.5	2.5	30	84	10°	FT02	STANDART YATAR	LU2B 1600	4.755,00
400	4.0	2.8	30	60	15°	2/10/60	STANDART YATAR	LU2A 3300	6.368,00
400	4.0	2.8	30	96	10°	2/10/60	STANDART YATAR	LU2B 1900	6.906,00
400	3.8	2.8	30	120	5°	2/10/60	OPTICUT KESİM	LU2C 2100	7.204,00
450	4.4	3.0	30	54	15°	2/10/60	STANDART YATAR	LU2A 3500	7.742,00
500	4.4	3.2	30	60	15°	2/10/60-80	STANDART YATAR	LU2A 3700	9.112,00
500	4.4	3.2	30	144	5°	2/10/60-80	OPTICUT KESİM	LU2C 2300	11.312,00



## İNCE AĞAÇ TESTERELERİ

Boyuna ve enine kesim için uygun testereler. Düşük kesme yüksekliği iş parçası beslemesini kolaylaştırır.

**Makineler:**  
Yatar makineler, taşınabilir makineler  
**Özellikler:**  
15° diş, pozitif kesme açılı

**Malzeme:**  
Yüksek kaliteli, yumuşak ve sert ağaç

D mm	B mm	b mm	d mm	Z	a°	NL	MAKİNE/AÇIKLAMA	ÜRÜN KODU	FİYAT
180	1.5	1.0	30	40	15°	2/7/42	GÖNYELEME YATAR	LU1H 0100	1.840,00
200	1.5	1.0	30	60	15°	2/7/42	GÖNYELEME YATAR	LU1H 0400	2.540,00
250	2.2	1.6	30	24	15°	FT01	STANDART YATAR	LCL5M 02019	1.800,00
250	2.5	1.6	30	24	15°	FT01	STANDART YATAR	LU1E 0100	1.830,00
250	2.5	1.6	30	48	15°	FT01	GÖNYELEME YATAR	LU1H 0700	2.405,00
250	2.5	1.6	30	60	15°	FT01	GÖNYELEME YATAR	LU1H 0800	2.805,00
300	2.7	1.8	30	28	15°	FT01	STANDART YATAR	LU1E 0300	2.490,00
350	3.0	2.2	30	32	15°	FT01	STANDART YATAR	LU1E 0400	3.100,00
350	3.0	2.2	30	84	15°	FT01	GÖNYELEME YATAR	LU1H 1300	4.410,00



## 45° KESİM TESTERELERİ

Enine kesim için uygun. Parçalanma olmadan mükemmel kesime sahip yüksek performanslı testere.

**Makineler:**

Tek ve çift kafalı gönye testere

**Özellikler:**

Düz ATB 15° diş, aksel 15° ve pozitif kesme açısı ile

**Malzeme:**

Yumuşak, sert ağaç, MDF ve Pleksiglas



D mm	B mm	b mm	d mm	Z	a°	NL	MAKİNE/AÇIKLAMA	ÜRÜN KODU	FİYAT
300	3.0	2.2	30	100	15°	FT01	S.YATAR/GÖNYE KESME	LU1L 0500	4.260,00
300	3.0	2.2	30	120	15°	FT01	S.YATAR/GÖNYE KESME	LU1L 0600	4.430,00
305	3.0	2.2	30	100	15°		S.YATAR/GÖNYE KESME	LU1L 1100	4.260,00
350	3.45	3.0	30	108	10°	FT02	S.YATAR/GÖNYE KESME	LU1I 0900	5.630,00
350	3.0	2.2	30	120	15°	FT01	S.YATAR/GÖNYE KESME	LU1L 0900	5.570,00

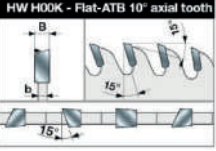

## ÇOKLU DİLME TESTERELERİ

Dilme için uygun testere.

**Makineler:**

Çoklu dilme makineleri

**Özellikler:**

ATB 10° diş

**Malzeme:**

%15 nem oranında kurutulmuş yumuşak ve sert ağaç

**Perma-SHIELD kaplama**

D mm	B mm	b mm	d mm	Z	a°	NL	MAKİNE/AÇIKLAMA	ÜRÜN KODU	FİYAT
250	3.2	2.2	70	20+2+2	20°		ÇOKLU DİLİMLEME	LM0425003	3.600,00
300	3.2	2.2	70	24+2+2	20°		ÇOKLU DİLİMLEME	LM0430003	4.370,00
300	3.2	2.2	75	24+2+2	20°		ÇOKLU DİLİMLEME	LM0430005	4.370,00
350	3.5	2.5	70	28+2+4	20°		ÇOKLU DİLİMLEME	LM0435005	5.400,00
350	3.5	2.5	75	28+2+4	20°		ÇOKLU DİLİMLEME	LM0435010	5.400,00
400	4.0	2.8	70	28+2+4	20°		ÇOKLU DİLİMLEME	LM0440002	6.750,00
400	4.0	2.8	75	28+2+4	20°		ÇOKLU DİLİMLEME	LM0440004	6.750,00

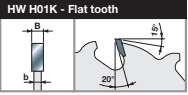
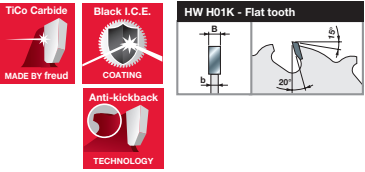

## TAŞINABİLİR MAKİNELER İÇİN TESTERELER

**Makineler:** Taşınabilir makineler

D mm	B mm	b mm	d mm	Z	Y	a°	MAKİNE/AÇIKLAMA	ÜRÜN KODU	FİYAT
160	1.7	1.3	20	16	16	15°	SUNTA KESME MAKİNASI	LCL5M 02023	915,00
180	1.7	1.3	30	20	16	15°	SUNTA KESME MAKİNASI	LCL5M 02024	935,00
184	1.7	1.3	30	40	20/16	15°	SUNTA KESME MAKİNASI	LCL5M 02040	1.210,00
190	1.7	1.3	30	30	20	15°	SUNTA KESME MAKİNASI	LCL5M 02039	1.170,00
210	1.7	1.3	30	32	25/20	15°	SUNTA KESME MAKİNASI	LCL5M 02026	1.230,00
235	1.7	1.3	30	32	25	15°	SUNTA KESME MAKİNASI	LCL5M 02042	1.380,00



## LSBX PANEL EBATLAMA TESTERELERİ

Tekli veya çoklu panelleri ölçülendirmek için

**Makineler:**

CNC Panel Ebatlama Makineleri için

**Özellikler:**

Pozitif kesme açısına sahip trapez diş

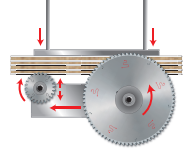
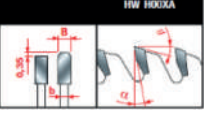
**Malzeme:**Suntalam, MDFlam, Kompakt Laminant,  
Termoplastik Kompozitler ve Pleksiglas

D mm	B mm	b mm	d mm	Z	a°	NL	MAKİNE/AÇIKLAMA	ÜRÜN KODU	FİYAT
300	4.4	3.0	30	60	15°	2/10/60	TURANLAR	LSB30001X	6.568,00
300	4.4	3.0	30	72	15°	2/10/60	TURANLAR	LSB30005X	7.011,00
320	4.4	3.2	65	72	15°	2/9/110, 2/9/95	SELCO, AYZA MIZRAK	LSB32001X	8.082,00
320	4.4	3.2	75	72	15°	3/13/95, 3/7/100	GİBEN, TÖRK	LSB32002X	8.082,00
320	4.4	3.2	30	72	15°	2/10/60, 2/13/94	MAYER, AES	LSB32009X	8.082,00
350	4.4	3.2	30	72	15°	2/10/60	HOLZER, MAYER	LSB35003X	7.986,00
350	4.4	3.2	60	72	15°	2/14/100	HOLZMA	LSB35004X	7.986,00
350	4.4	3.2	80	72	15°	4/9/100, 2/9/110, 2/14/110	GABBİANI	LSB35005X	7.986,00
350	4.4	3.2	50	72	15°	4/13/80	GİBEN	LSB35006X	8.570,00
355	4.4	3.2	30	72	15°	2/10/60	HOLZER, MAYER	LSB35504X	8.570,00
355	4.4	3.2	75	72	15°	4/15/105, 2/7/110	GİBEN, KDT, HOLD	LSB35505X	8.570,00
355	4.4	3.2	75	72	15°	3/7/100	MATMAZZE, GABBİANI	LSB35507X	8.570,00
360	4.4	3.2	65	72	15°	2/9/110, 2/9/95	SELCO, AYZA MIZRAK	LSB36002X	8.774,00
360	4.4	3.2	30	72	15°	2/13/94	SHELLING	LSB36003X	8.774,00
380	4.4	3.2	60	72	15°	2/14/100	HOLZMA	LSB38002X	9.652,00
380	4.8	3.5	60	72	15°	2/14/100	HOLZMA	LSB38004X	10.091,00
380	4.8	3.5	60	84	15°	2/14/100	HOLZMA	LSB38005X	10.333,00
380	4.4	3.2	50	72	15°	4/13/80	GİBEN	LSB38008X	8.867,00
380	4.4	3.2	80	72	15°	4/9/100, 2/9/110, 2/14/110	GABBİANI	LSB38010X	8.867,00
380	4.4	3.2	30	72	15°	2/8/83, 2/10/60		LSB38011X	8.867,00
380	4.4	3.2	75	72	15°	2/14/100	HOLZMA	LSB38012X	8.867,00
380	4.4	3.2	80	96	15°	4/9/100, 2/9/110, 2/14/110	GABBİANI	LSB38013X	10.431,00
380	4.4	3.2	65	72	15°	2/9/110	SELCO	LSB38014X	8.867,00
400	4.4	3.2	30	72	15°	2/10/60, 2/13/94	HOLZER, SCHEER, AES, SCHELLING	LSB40007X	9.112,00
400	4.4	3.2	75	72	15°	4/15/105, 2/7/110, 2/14/100	GİBEN, SAWTECH, KDT	LSB40008X	9.112,00
400	4.4	3.2	80	72	15°	2/15/105, 2/9/130, 4/19/120	SELCO	LSB40009X	9.112,00
400	4.4	3.2	80	72	15°	4/9/100, 2/9/110, 2/14/110, 2/14/125	GABBİANI, TURANLAR	LSB40012X	9.112,00
400	4.4	3.2	65	72	15°	2/9/110	SELCO	LSB40016X	9.112,00
420	4.8	3.5	60	84	15°	2/14/100, 2/14/125	HOLZMA	LSB42002X	12.982,00
430	4.4	3.2	30	72	15°	2/13/94	AES	LSB43007X	11.461,00
430	4.4	3.2	75	72	15°	4/15/105, 2/7/110	GİBEN	LSB43008X	10.188,00
430	4.4	3.2	80	72	15°	2/9/130, 2/14/110, 4/19/120	SELCO, GABBİANI	LSB43009X	10.333,00
430	4.4	3.2	65	72	15°	2/9/110	SELCO	LSB43012X	10.238,00
450	4.4	3.2	30	72	15°	2/10/60, 2/14/95	MAYER	LSB45007X	11.176,00
450	4.4	3.2	80	72	15°	2/9/130, 2/14/110, 4/19/120	SELCO, GABBİANI	LSB45009X	11.176,00
450	4.8	3.5	30	72	15°	2/9/60	SCHEER	LSB45016X	11.402,00
450	4.8	3.5	60	72	15°	2/14/125, 2/17/100	HOLZMA, NANXING	LSB45017X	11.402,00
450	4.8	3.5	80	72	15°	2/9/130, 4/19/120, 2/14/125	SELCO	LSB45018X	11.402,00
450	4.8	3.5	60	84	15°	2/14/125	HOLZMA	LSB45019X	12.978,00
460	4.4	3.2	30	72	15°	2/13/94	SHELLING	LSB46001X	12.000,00
470	4.4	3.2	75	96	15°	4/15/105	GİBEN	LSB47004X	16.159,00
470	4.8	3.5	70	72	15°	4/11/130	SELCO	LSB47005X	13.568,00
520	4.8	3.5	60	72	15°	2/11/115, 2/19/120	HOLZMA	LSB52003X	14.572,00
520	4.8	3.5	70	72	15°	4/11/130	SELCO	LSB52006X	14.572,00
520	4.8	3.5	30	72	15°	2/13/94	SHELLING	LSB52007X	14.572,00
600	5.8	4.0	60	72	15°	2/11/115, 2/19/120	HOLZMA	LSB60002X	18.314,00



## LI25 PANEL EBATLAMA ÇİZİCİLERİ

Çift lamineli panellerde kaplamayı çizmek için

## Makineler:

CNC Panel Ebatlama Makineleri için

## Özellikler:

ATB 6° dış, pozitif kesme açılı

## Malzeme:

Çift lamine suntalam ve mdf lam

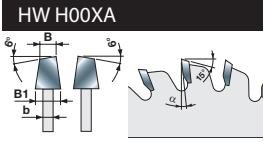

D mm	B mm	b mm	d mm	Z	α°	NL	MAKİNE/AÇIKLAMA	ÜRÜN KODU	FİYAT
125	4.3-5.5	3.2	20	24	0°		GABBİANI, PANHANS	LI25M43 FA3	3.186,00
125	4.3-5.5	3.2	45	24	0°		GİBEN, HOMAG	LI25M43 FE3	3.186,00
150	4.3-5.6	3.2	30	36	8°		SCM, TURANLAR	LI25M43 KC3	4.067,00
150	4.3-5.6	3.2	45	36	8°		SCM, HOLZMA, HOMAG	LI25M43 KE3	4.067,00
160	4.3-5.5	3.2	45	36	8°	3/11/70	GİBEN	LI25M43 LE3	4.214,00
160	4.3-5.5	3.2	55	36	8°	3/6/84 + 3/7/66	GABBİANI, TÖRK	LI25M43 LG3	4.314,00
180	4.3-5.5	3.2	30	28	8°	2/7/42 + 2/10/60	HOLZER	LI25M43 NC3	4.067,00
180	4.3-5.5	3.2	30	36	8°	2/7/42 + 2/10/60	HOLZER	LI25M43 XN3	4.460,00
180	4.3-5.5	3.2	45	36	8°		HOLZMA	LI25M43 NE3	4.460,00
180	4.3-5.5	3.2	50	36	8°	3/13/80	GİBEN	LI25M43 NF3	4.900,00
180	4.7-5.9	3.5	45	36	8°		HOLZMA	LI25M47 NE3	4.900,00
200	4.3-5.5	3.2	20	36	8°	2/11/66 + 2/10/60 + 2/9/62	SHELLING, AES	LI25M43 PA3	4.460,00
200	4.3-5.5	3.2	30	36	8°	2/9/60 + 2/10/60	SCHER	LI25M43 PC3	4.410,00
200	4.3-5.5	3.2	45	36	8°		HOLZMA	LI25M43 PE3	4.410,00
200	4.3-5.5	3.2	50	36	8°	2/7/80 + 3/13/80	GİBEN, SAWTECH	LI25M43 PF3	4.755,00
200	4.3-5.5	3.2	65	36	8°	2/9/100 + 2/9/110	SELCO	LI25M43 PI3	4.755,00
200	4.3-5.5	3.2	80	36	8°	2/14/110	GABBİANI, SCM	LI25M43 PL3	4.410,00
200	4.7-5.9	3.5	20	36	8°	2/11/66	SHELLING	LI25M47 PA3	4.652,00
200	4.7-5.9	3.5	45	36	8°		HOLZMA	LI25M47 PE3	4.652,00
200	4.7-5.9	3.5	65	36	8°	2/9/100 + 2/9/110	SELCO	LI25M47 PI3	4.998,00
200	5.7-6.9	4.0	45	36	8°		HOLZMA	LI25M57 PE3	5.088,00
215	4.3-5.5	3.2	50	42	8°	2/7/80 + 3/15/80	GİBEN	LI25M43 QF3	6.323,00
300	4.3-5.5	3.2	65	72	12°	2/9/110 + 2/9/100	SELCO	LI25M43 RI3	8.329,00
300	4.3-5.5	3.2	80	72	12°	2/14/110	GABBİANI	LI25M43 RL3	8.329,00
300	4.7-5.9	3.5	65	48	6°	2/9/110	SELCO	LI25M47 RX3	7.303,00

## DLI25M DİA PANEL EBATLAMA ÇİZİCİLERİ

Çift lamineli panellerde kaplamayı çizmek için. Son derece uzun kullanım ömrü.

## Makineler:

CNC Panel Ebatlama Makineleri için

## Özellikler:

Pozitif kesme açısına sahip PCD(dia) düz diş

## Malzeme:

Çift lamine suntalam ve mdf lam

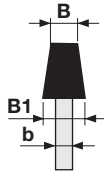

D mm	B mm	b mm	d mm	Z	α°	NL	MAKİNE/AÇIKLAMA	ÜRÜN KODU	FİYAT
120	2.8-3.6	2.2	20	24	6°		SHELLING	DLI25M28 EAH4	14.800,00
125	3.1-3.9	2.2	20	24	6°		PANHANS SHELLING	DLI25M31 FAH4	16.100,00
180	4.7-5.5	3.5	45	30	6°		HOLZMA	DLI25M47 NEH4	27.000,00
200	4.3-5.1	3.2	65	36	6°	2/9/100 + 2/9/110	SELCO	DLI25M43 PIH4	30.200,00
200	4.3-5.1	3.2	80	36	6°	2/14/110	GABBİANI	DLI25M43 PLH4	30.200,00

\*H4-4 kere bilenir.

D mm	B mm	b mm	d mm	Z	α°	NL	MAKİNE/AÇIKLAMA	ÜRÜN KODU	FİYAT
120	2.8-3.6	2.2	20	24	6°		SHELLING	DLI25M28 EAH6	19.100,00
125	3.1-3.9	2.2	20	24	6°		PANHANS SHELLING	DLI25M31 FAH6	20.700,00
180	4.7-5.5	3.5	45	30	6°		HOLZMA	DLI25M47 NEH6	35.000,00
200	4.3-5.1	3.2	65	36	6°	2/9/100 + 2/9/110	SELCO	DLI25M43 PIH6	39.000,00
200	4.3-5.1	3.2	80	36	6°	2/14/110	GABBİANI	DLI25M43 PLH6	39.000,00

\*H6-6 kere bilenir.

## EL TİPİ DAİRE TESTERE MAKİNELERİ İÇİN AHŞAP KESİM TESTERELERİ

freud

**Makineler:** Portatif el tipi daire testere makineleri için  
**Özellikler:** Pozitif kesim açısına sahip ATB (sağ-sol) diş

**Malzeme:** Yumuşak ve sert ağaç, sunta, mdf, kontrplak

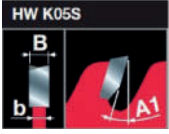

D mm	B mm	b mm	d mm	Z	a°	MAKİNE/AÇIKLAMA	ÜRÜN KODU	FİYAT
160	2.4	1.6	16	24	15°	EL TİPİ DAİRE TESTERE MAKİNELERİ	FR06W 001H	1.279,00
160	2.4	1.6	20	24	15°	EL TİPİ DAİRE TESTERE MAKİNELERİ	FR06W 009H	1.279,00
160	2.4	1.6	20	48	5°	EL TİPİ DAİRE TESTERE MAKİNELERİ	FR06W 011H	1.390,00
165	2.4	1.6	20	24	15°	EL TİPİ DAİRE TESTERE MAKİNELERİ	FR07W 003H	1.344,00
180	2.4	1.6	30	24	15°	EL TİPİ DAİRE TESTERE MAKİNELERİ	FR09W 003H	1.382,00
180	2.4	1.6	30	48	5°	EL TİPİ DAİRE TESTERE MAKİNELERİ	FR09W 004H	1.449,00
184	2.4	1.6	16	40	10°	EL TİPİ DAİRE TESTERE MAKİNELERİ	FR11W 002H	1.579,00
184	2.4	1.6	30	24	15°	EL TİPİ DAİRE TESTERE MAKİNELERİ	FR11W 007H	1.431,00
190	2.4	1.6	30	24	15°	EL TİPİ DAİRE TESTERE MAKİNELERİ	FR13W 006H	1.304,00
190	2.4	1.6	30	40	10°	EL TİPİ DAİRE TESTERE MAKİNELERİ	FR13W 007H	1.672,00
190	2.4	1.6	30	48	10°	EL TİPİ DAİRE TESTERE MAKİNELERİ	FR13W 008H	1.579,00
210	2.4	1.8	30	24	15°	EL TİPİ DAİRE TESTERE MAKİNELERİ	FR15W 003H	1.372,00
210	2.4	1.8	30	40	15°	EL TİPİ DAİRE TESTERE MAKİNELERİ	FR15W 001H	1.750,00
210	2.4	1.8	30	48	10°	EL TİPİ DAİRE TESTERE MAKİNELERİ	FR15W 004H	1.683,00
230	2.8	1.8	30	24	15°	EL TİPİ DAİRE TESTERE MAKİNELERİ	FR19W 001H	1.458,00
230	2.8	1.8	30	36	15°	EL TİPİ DAİRE TESTERE MAKİNELERİ	FR19W 002H	1.902,00
230	2.8	1.8	30	48	15°	EL TİPİ DAİRE TESTERE MAKİNELERİ	FR19W 003H	1.838,00
235	2.8	1.8	30	48	15°	EL TİPİ DAİRE TESTERE MAKİNELERİ	FR20W 005H	2.158,00

## GÖNYE KESME MAKİNELERİ İÇİN AHŞAP KESİM TESTERELERİ

freud

**Makineler:** Gönye kesme makineleri için  
**Özellikler:** Negatif kesim açısına sahip ATB (sağ-sol) diş

**Malzeme:** Yumuşak ve sert ağaç, sunta, mdf, kontrplak



D mm	B mm	b mm	d mm	Z	a°	AÇIKLAMA	ÜRÜN KODU	FİYAT
260	2.4	1.8	30	60	-5°	GÖNYE KESME MAKİNELERİ	FR26W 001M	3.167,00

## EL TİPİ DAİRE TESTERE MAKİNELERİ İÇİN ÇİVİLİ AHŞAP KESİM TESTERELERİ

freud

**Makineler:** Portatif el tipi daire testere makineleri için  
**Özellikler:** Pozitif kesim açısına sahip ATB (sağ-sol) diş

**Malzeme:** Çivili ahşap, sunta

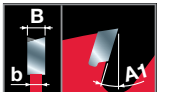
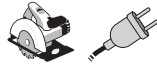

D mm	B mm	b mm	d mm	Z	a°	AÇIKLAMA	ÜRÜN KODU	FİYAT
160	2.0	1.3	20	14	18°	EL TİPİ DAİRE TESTERE MAKİNELERİ	FR06C 001H	1.120,00
165	2.0	1.3	20	14	18°	EL TİPİ DAİRE TESTERE MAKİNELERİ	FR07C 001H	1.160,00
180	2.0	1.3	30	14	18°	EL TİPİ DAİRE TESTERE MAKİNELERİ	FR09C 001H	1.212,00
184	2.0	1.3	16	14	18°	EL TİPİ DAİRE TESTERE MAKİNELERİ	FR11C 001H	1.265,00
190	2.0	1.3	30	14	18°	EL TİPİ DAİRE TESTERE MAKİNELERİ	FR13C 001H	1.333,00
210	2.0	1.3	30	16	18°	EL TİPİ DAİRE TESTERE MAKİNELERİ	FR15C 001H	1.474,00
230	2.2	1.6	30	20	18°	EL TİPİ DAİRE TESTERE MAKİNELERİ	FR19C 001H	1.712,00
235	2.2	1.6	30	20	18°	EL TİPİ DAİRE TESTERE MAKİNELERİ	FR20C 001H	1.726,00

## JİLET BIÇAKLAR



L mm	H mm	S mm	I mm	KESKİN TARAF	MAKİNE/AÇIKLAMA	ÜRÜN KODU	FİYAT
7.6	12	1.5		2 TARAFI KESKİN	FREZE JİLETİ	CG08M AA310	74,00
12	12	1.5		4 TARAFI KESKİN	FREZE JİLETİ	CG08M BA310	115,00
14	14	2		4 TARAFI KESKİN	FREZE JİLETİ	RG01M AA310	116,00
15	12	1.5		2 TARAFI KESKİN	FREZE JİLETİ	CG08M CA310	92,00
20	12	1.5		2 TARAFI KESKİN	FREZE JİLETİ	CG08M DA310	79,00
30	12	1.5	14	2 TARAFI KESKİN	FREZE JİLETİ	CG08M EA310	102,00
40	12	1.5	26	2 TARAFI KESKİN	FREZE JİLETİ	CG08M LA310	160,00
50	12	1.5	26	2 TARAFI KESKİN	FREZE JİLETİ	CG08M FA310	133,00
50	12	1.5	26	4 TARAFI KESKİN	FREZE JİLETİ	CG71M AA310	449,00
60	12	1.5	26	2 TARAFI KESKİN	FREZE JİLETİ	CG08M GA310	199,00



L mm	H mm	S mm	I mm	KESKİN TARAF	MAKİNE/AÇIKLAMA	ÜRÜN KODU	FİYAT
30	12	1.5	14	2 TARAFI KESKİN	FREZE JİLETİ	CG20M EA310	137,00
50	12	1.5	26	2 TARAFI KESKİN	FREZE JİLETİ	CG20M FA310	173,00

## PLANYA BIÇAĞI



L mm	A mm	E mm	AÇIKLAMA	ÜRÜN KODU	FİYAT
82	5.5	1.1	2'Lİ PAKET	60635	277,00

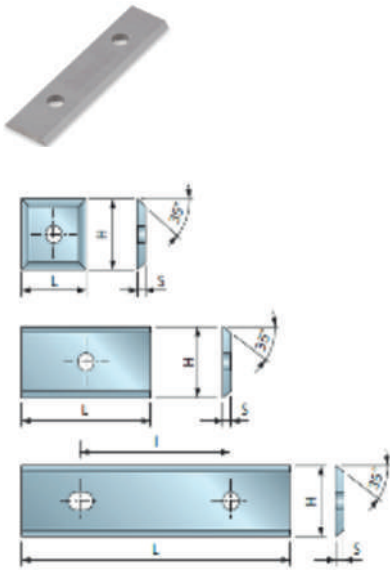

KOD	KULLANIM ALANI								HW	SERTLİK	
	Universal	Yumuşak Ağaç	Sert Ağaç	Kontrplak	Lamine	MDF	HDF	Plastik			
35° CG20M*	-	-	-	-	●	●	●	●	H00XF	▲	2300
35° CG04M*	-	-	-	◐	◑	◑	◑	-	H00XA	■	2070
35° CG05M	-	-	-	◐	◑	◑	-	-	H00K	◆	1960
35° CG26M	◐	◑	◑	-	◑	◑	-	◑	H01K	●	1870
35° CG01M - CG10M	●	◑	◑	◑	◑	◑	-	◑	H00S	▶	1860
35° CG08M	●	◑	◑	◑	◑	◑	-	◑	K01S	◆	1850
35° CG19M	●	◑	◑	◑	◑	◑	-	◑	H00S	▶	1860
40° CG76M	-	◑	●	-	-	◑	-	-	H01K	●	1870
40° CG66M	-	◑	◑	-	-	◑	-	-	X10TS	▲	1650
40° CG06M	-	◑	◑	-	-	-	-	-	K30S	●	1430
40° CG17M	-	-	●	-	-	-	-	-	K10S	◆	1620
40° CG18M	-	◑	◑	-	-	-	-	-	K30S	●	1430
45° CG62M	-	●	◑	-	-	-	-	-	X10TS	▲	1650
45° CG22M	-	◑	◑	-	-	-	-	-	K30S	●	1430

\*Yabancı maddeler içeren panolar için değildir.

● Maksimum performans ◐ Yüksek performans ◑ Standart performans ◑ Temel performans - Tavsiye edilmez

## ALÜMİNYUM TESTERELERİ

## Makineler:

Parçanın manuel ya da mekanik olarak bağlandığı gönye testereler

## Malzeme:

Alüminyum ve demir olmayan metaller, PVC enjeksiyon profilleri

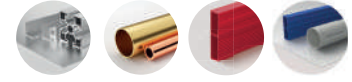
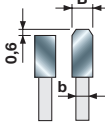

D mm	B mm	b mm	d mm	Z	a°	NL	MAKİNE/AÇIKLAMA	ÜRÜN KODU	FİYAT
200	2.8	2.2	30	64	5°		GÖNYELEME-OTM PROFİL	LU5B 0100	2.556,00
250	2.8	2.2	30	80	5°	FT02	GÖNYELEME-OTM PROFİL	LU5B 0201	2.739,00
250	2.8	2.0	30	80	-5°	FT121	GÖNYELEME-OTM PROFİL	FR23A 001M	2.739,00
300	3.0	2.5	30	96	5°	FT02	GÖNYELEME-OTM PROFİL	LU5B 0801	3.026,00
300	2.8	2.0	30	96	-5°	FT121	GÖNYELEME-OTM PROFİL	FR28 A001M	3.026,00
350	3.5	3.0	30	108	-6°	FT02	GÖNYELEME-OTM PROFİL	LU5D 1700	4.719,00
400	3.5	3.0	30	96	-6°	2/11/70	GÖNYELEME-OTM PROFİL	LU5C 1800	5.669,00
400	3.5	3.0	32	96	-6°	2/11/63	GÖNYELEME-OTM PROFİL	LU5C 1900	5.669,00
400	3.5	3.0	30	120	-6°		GÖNYELEME-OTM PROFİL	LU5D 2300	5.863,00
400	3.5	3.0	32	120	-6°	2/11/63	GÖNYELEME-OTM PROFİL	LU5D 2400	5.863,00
420	4.0	3.2	30	96	-6°	2/11/70	GÖNYELEME-OTM PROFİL	LU5C 2200	7.203,00
420	4.0	3.2	30	120	-6°	2/11/70	GÖNYELEME-OTM PROFİL	LU5D 2700	7.911,00
450	4.0	3.2	30	108	-6°		GÖNYELEME-OTM PROFİL	LU5C 2400	8.300,00
450	4.0	3.2	32	108	-6°	2/11/63	GÖNYELEME-OTM PROFİL	LU5C 2500	8.300,00
450	4.0	3.0	32	128	5°	2/11/63	GÖNYELEME-OTM PROFİL	LU5B 2800	8.300,00
500	4.0	3.2	30	120	-6°		GÖNYELEME-OTM PROFİL	LU5C 2800	9.034,00
500	4.0	3.2	32	120	-6°	2/11/63	GÖNYELEME-OTM PROFİL	LU5C 2900	10.038,00
500	4.0	3.2	32	140	5°	2/11/63	GÖNYELEME-OTM PROFİL	LU5B 3200	11.521,00
550	4.2	3.5	30	132	10°	2/10,5/70	GÖNYELEME-OTM PROFİL	LU5A 2900	11.958,00

## ALÜMİNYUM TESTERELERİ LU5F ÖZEL SERİ

İçlerindeki plastik profiller ile birlikte kapılar ve pencereler için 4,5 mm'ye kadar ince duvarlı alüminyum profilleri kesmek için testere bıçakları

## Makineler:

Tek ve çift başlı makineler

## Özellikler:

PIRAMİT dış tasarımı, kesme kenarındaki aşınmayı belirgin biçimde azaltan bir geometri konseptine sahiptir. Süper cıvalı kesme kenarları alüminyum talaşların yüzeye yapışmasını daha da azaltır. Siyah Exrim kaplama alüminyum talaşları kanallardan hemen boşaltır. Talaşların çelik gövdeye kaynaklanmasını ve yüzeyin matlaşmasını engeller.

## Malzeme:

Alüminyum ve demir olmayan metaller, PVC enjeksiyon profilleri

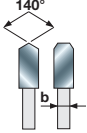

D mm	B mm	b mm	d mm	Z	a°	NL	AÇIKLAMA	ÜRÜN KODU	FİYAT
600	4.7	4.0	30	144	7°	2/11/63 - 2/11/70	HASSAS KESİM	LU5F 60001	19.308,00
600	4.7	4.0	32	144	7°	2/11/63 - 2/11/70	HASSAS KESİM	LU5F 60002	19.308,00

## DEMİR TESTERELERİ

Çekilmiş ürünleri, boruları ve demir çubukları kesmek için

## Makineler:

Düşük güçlü kuru kesmede gönye testereler (yağ olmadan)

## Özellikler:

Çift-trapez diş

## Malzeme:

Demir içeren metaller, yumuşak çelik, bakır vb. için

**UYARI:** Yukarıda bahsedilen testereler aşağıdaki malzemeleri kesmek için uygun değildir:

- Demirli olmayan metaller (Alüminyum)
- Ağaç, cam, yığın vb.

Kesilecek olan iş parçalarının doğru bağlandığına emin olun.

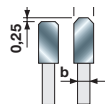

D mm	B mm	b mm	d mm	Z	a°	MAKİNE/AÇIKLAMA	ÜRÜN KODU	FİYAT
305	2.6	2.2	25.4	60	0°	METAL GÖNYE TESTERELERİ	LU6A 1100	4.816,00
305	2.6	2.2	25.4	80	0°	METAL GÖNYE TESTERELERİ	LU6A 1200	5.252,00
355	2.6	2.2	25.4	72	0°	METAL GÖNYE TESTERELERİ	LU6A 1500	5.252,00
355	2.6	2.2	25.4	90	0°	METAL GÖNYE TESTERELERİ	LU6A 1600	6.387,00

## EL TİPİ DAİRE TESTERE MAKİNELERİ İÇİN ALÜMİNYUM KESİM TESTERELERİ

freud

**Makineler:** Gönye kesme makineleri için  
**Özellikler:** -5° kesim açısına sahip düz-trapez diş

**Malzeme:** Alüminyum, plastik, bakır ve piriç



D mm	B mm	b mm	d mm	Z	a°	MAKİNA/AÇIKLAMA	ÜRÜN KODU	FİYAT
160	2.2	1.6	20	52	-5°	EL TİPİ DAİRE TESTERE MAKİNELERİ	FR06A 001H	1.932,00
165	2.5	1.6	20	52	-5°	EL TİPİ DAİRE TESTERE MAKİNELERİ	FR07A 001H	2.147,00
180	2.5	1.6	30	56	-5°	EL TİPİ DAİRE TESTERE MAKİNELERİ	FR09A 001H	2.172,00
190	2.5	1.6	30	56	-5°	EL TİPİ DAİRE TESTERE MAKİNELERİ	FR13A 002H	2.172,00
210	2.3	1.8	30	72	-5°	EL TİPİ DAİRE TESTERE MAKİNELERİ	FR15A 001H	2.669,00
230	2.8	1.8	30	64	-5°	EL TİPİ DAİRE TESTERE MAKİNELERİ	FR19A 001H	2.783,00
235	2.5	1.8	30	80	-5°	EL TİPİ DAİRE TESTERE MAKİNELERİ	FR20A 001H	3.000,00

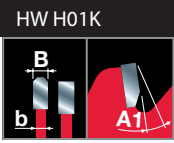

## GÖNYE KESME MAKİNELERİ İÇİN ALÜMİNYUM KESİM TESTERELERİ

freud

**Makineler:** Gönye kesme makineleri için  
**Özellikler:** -5° kesim açısına sahip düz-trapez diş

**Malzeme:** Alüminyum, plastik, bakır ve piriç



D mm	B mm	b mm	d mm	Z	a°	MAKİNA/AÇIKLAMA	ÜRÜN KODU	FİYAT
210	2.5	1.8	30	54	-5°	GÖNYE KESME MAKİNELERİ	FR15A 001M	2.262,00
216	2.5	1.8	30	64	-5°	GÖNYE KESME MAKİNELERİ	FR16A 001M	2.461,00
250	2.8	2.0	30	80	-5°	GÖNYE KESME MAKİNELERİ	FR23A 001M	2.739,00
260	2.3	1.8	30	80	-5°	GÖNYE KESME MAKİNELERİ	FR26A 001M	2.890,00
300	2.8	2.0	30	96	-5°	GÖNYE KESME MAKİNELERİ	FR28A 001M	3.026,00

## EL TİPİ DAİRE TESTERE MAKİNELERİ İÇİN ÇOKLU MATERYAL KESİM TESTERELERİ

freud

**Makineler:** Portatif el tipi daire testere makineleri için  
**Özellikler:** 0° kesim açısına sahip trapez-trapez diş

**Malzeme:** Sunta, mdf, kontrplak alüminyum, plastik, bakır ve piriç, ince demir profil



D mm	B mm	b mm	d mm	Z	a°	MAKİNA/AÇIKLAMA	ÜRÜN KODU	FİYAT
160	2.0	1.6	20	30	0°	EL TİPİ DAİRE TESTERE MAKİNELERİ	FR06M 001H	2.158,00
184	2.0	1.6	30	36	0°	EL TİPİ DAİRE TESTERE MAKİNELERİ	FR11M 001H	2.631,00
190	2.0	1.6	30	38	0°	EL TİPİ DAİRE TESTERE MAKİNELERİ	FR13M 001H	2.684,00
230	2.4	2.0	30	44	0°	EL TİPİ DAİRE TESTERE MAKİNELERİ	FR19M 001H	3.355,00

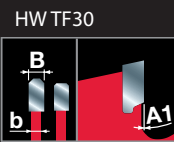

## GÖNYE KESME MAKİNELERİ İÇİN ÇOKLU MATERYAL KESİM TESTERELERİ

freud

**Makineler:** Gönye kesme makineleri için  
**Özellikler:** 0° kesim açısına sahip trapez-trapez diş

**Malzeme:** Sunta, mdf, kontrplak alüminyum, plastik, bakır ve piriç, ince demir profil



D mm	B mm	b mm	d mm	Z	a°	MAKİNA/AÇIKLAMA	ÜRÜN KODU	FİYAT
210	2.0	1.6	30	40	0°	GÖNYE KESME MAKİNELERİ	FR15M 001M	2.880,00
216	2.0	1.6	30	40	0°	GÖNYE KESME MAKİNELERİ	FR16M 001M	2.921,00
250	2.4	2.0	30	48	0°	GÖNYE KESME MAKİNELERİ	FR23M 001M	3.742,00
300	2.6	2.0	30	80	0°	GÖNYE KESME MAKİNELERİ	FR28M 001M	5.183,00

## EL TİPİ DAİRE TESTERE MAKİNELERİ İÇİN SANDWICH PANEL KESİM TESTERELERİ

freud

**Makineler:** Portatif el tipi daire testere makineleri için  
**Özellikler:** 0° kesim açısına sahip trapez-trapez diş

**Malzeme:** Sandwich panel



D mm	B mm	b mm	d mm	Z	a°	MAKİNA/AÇIKLAMA	ÜRÜN KODU	FİYAT
160	2.0	1.6	20	30	0°	EL TİPİ DAİRE TESTERE MAKİNELERİ	FR06X 001H	1.661,00
165	2.0	1.6	20	30	0°	EL TİPİ DAİRE TESTERE MAKİNELERİ	FR07X 001H	1.763,00
190	2.0	1.6	30	36	0°	EL TİPİ DAİRE TESTERE MAKİNELERİ	FR13X 001H	2.147,00
210	2.4	2.0	30	36	0°	EL TİPİ DAİRE TESTERE MAKİNELERİ	FR15X 001H	2.287,00
230	2.2	1.8	30	48	0°	EL TİPİ DAİRE TESTERE MAKİNELERİ	FR19X 001H	2.552,00
235	2.2	1.8	30	50	0°	EL TİPİ DAİRE TESTERE MAKİNELERİ	FR20X 001H	2.764,00
270	2.4	2.0	30	60	0°	EL TİPİ DAİRE TESTERE MAKİNELERİ	FR27X 001H	4.021,00
350	2.9	2.5	30	60	0°	EL TİPİ DAİRE TESTERE MAKİNELERİ	FR32X 001H	5.080,00
355	2.6	2.2	30	80	0°	EL TİPİ DAİRE TESTERE MAKİNELERİ	FR33X 001H	5.494,00



## EL TİPİ DAİRE TESTERE MAKİNELERİ İÇİN BETOPAN KESİM TESTERELERİ

freud

**Makineler:** Portatif el tipi daire testere makineleri için  
**Özellikler:** 10° kesim açısına sahip PCD (Polycrystalline Diamond) trapez diş

**Malzeme:** Fibre cement (betopan), alçıpan



D mm	B mm	b mm	d mm	Z	a°	MAKİNA/AÇIKLAMA	ÜRÜN KODU	FİYAT
184	2.2	1.6	30	4	10°	EL TİPİ DAİRE TESTERE MAKİNELERİ	FR11F 001H	3.876,00
235	2.2	1.6	30	6	10°	EL TİPİ DAİRE TESTERE MAKİNELERİ	FR20F 001H	5.408,00



## GÖNYE KESME MAKİNELERİ İÇİN BETOPAN KESİM TESTERELERİ

freud

**Makineler:** Gönye kesme makineleri için  
**Özellikler:** 10° kesim açısına sahip PCD (Polycrystalline Diamond) trapez diş

**Malzeme:** Fibre cement (betopan), alçıpan



D mm	B mm	b mm	d mm	Z	a°	MAKİNA/AÇIKLAMA	ÜRÜN KODU	FİYAT
254	2.4	1.8	30	6	10°	GÖNYE KESME MAKİNELERİ	FR24F 001M	5.994,00
305	2.4	1.8	30	8	10°	GÖNYE KESME MAKİNELERİ	FR29F 001M	7.255,00

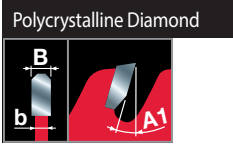

## EL TİPİ DAİRE TESTERE MAKİNELERİ İÇİN KOMPAKT LAMİNAT KESİM TESTERELERİ

**Makineler:** Portatif el tipi daire testere makineleri için  
**Özellikler:** 0° kesim açısına sahip düz-trapez diş

**Malzeme:** Kompakt laminat, corian

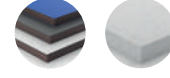

D mm	B mm	b mm	d mm	Z	a°	MAKİNE/AÇIKLAMA	ÜRÜN KODU	FİYAT
160	2.2	1.6	20	48	0°	EL TİPİ DAİRE TESTERE MAKİNELERİ	FR06H 001H	2.018,00
165	2.6	1.6	20	48	0°	EL TİPİ DAİRE TESTERE MAKİNELERİ	FR07H 001H	2.094,00
190	2.6	1.6	30	56	0°	EL TİPİ DAİRE TESTERE MAKİNELERİ	FR13H 002H	2.553,00
210	2.8	1.8	30	60	0°	EL TİPİ DAİRE TESTERE MAKİNELERİ	FR15H 001H	2.770,00
235	2.8	1.8	30	64	0°	EL TİPİ DAİRE TESTERE MAKİNELERİ	FR20H 001H	3.064,00

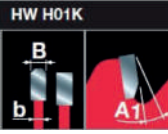

## GÖNYE KESME MAKİNELERİ İÇİN KOMPAKT LAMİNAT KESİM TESTERELERİ

**Makineler:** Gönye kesme makineleri için  
**Özellikler:** 0° kesim açısına sahip düz-trapez diş

**Malzeme:** Kompakt laminat, corian

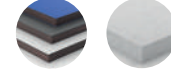

D mm	B mm	b mm	d mm	Z	a°	AÇIKLAMA	ÜRÜN KODU	FİYAT
250	2.8	1.8	30	80	-3°	GÖNYE KESME MAKİNELERİ	FR23H 001M	3.626,00
305	3.2	2.2	30	96	-3°	GÖNYE KESME MAKİNELERİ	FR29H 001M	4.392,00

## DÜZ KARBÜR VE HW FREZE BIÇAKLARI

## Makineler:

El tipi yönlendiriciler, masa yönlendiriciler ve CNC makineleri

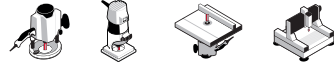

## Malzeme:

Yumuşak ve sert ağaç, kontrplak ve ahşap paneller

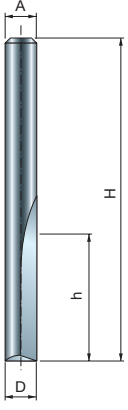

## Tip A Komple Karbürler

D mm	h mm	H mm	A mm	Z	MAKSİMUM DEVİR	AÇIKLAMA	ÜRÜN KODU	FİYAT
3	12	50	6	2	24.000		R006M03006	889,00
4	15.8	50.7	6	2	24.000		04-10106P	732,00
5	16	51	6	2	24.000		R006M07406	977,00
6	25	63	6	2	24.000		R006M10206	1046,00

## Tip B Gömmeli Karbürler

D mm	h mm	H mm	A mm	Z	MAKSİMUM DEVİR	AÇIKLAMA	ÜRÜN KODU	FİYAT
3	8	58	12	2	24.000		12-09612P	1.020,00
4	10	58	12	2	24.000		12-09712P	1.084,00
5	12.7	57	12	2	24.000		12-09812P	1.086,00
6	19	64	12	2	24.000		12-09912P	1.000,00

## Tip C HW Frezeler

D mm	h mm	H mm	A mm	Z	MAKSİMUM DEVİR	AÇIKLAMA	ÜRÜN KODU	FİYAT
8	19.1	52	6	2	24.000		04-11506P	663,00
10	25.4	62.4	6	2	24.000		MM-01006P	732,00
12	19	55.5	6	2	24.000		04-13506P	698,00
14	19	56	6	2	24.000		04-14306P	734,00
16	19	51	6	2	24.000		04-14906P	760,00
20	19	56	6	2	24.000		04-15506P	789,00
7	18	67	12	2	24.000		12-10312P	760,00
8	31.8	76	12	2	24.000		12-10712P	855,00
9	31.8	76	12	2	24.000		12-11012P	827,00
10	31.8	76	12	2	24.000		12-11212P	837,00
12	38.1	80	12	2	24.000		12-12212P	837,00
12	50.5	98	12	2	24.000		12-12812P	898,00
14	31.8	73	12	2	24.000		12-13412P	870,00
15	31.8	69.8	12	2	24.000		12-13512P	907,00
16	38.1	76.1	12	2	24.000		12-14012P	941,00
18	38.1	80	12	2	24.000		12-14312P	998,00
19	25.4	63.4	12	2	24.000		12-15212P	928,00
20	38.1	80	12	2	24.000		12-15912P	1.074,00
22	38.1	80	12	2	24.000		12-16912P	1.134,00

## ÜSTTEN RULMANLI FREZE BIÇAĞI

## Makineler:

El tipi yönlendiriciler ve masa yönlendiriciler



## Malzeme:

Yumuşak ve sert ağaç, kontrplak ve ahşap paneller

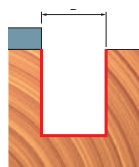
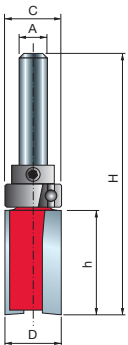

D mm	h mm	H mm	A mm	Z	AÇIKLAMA	ÜRÜN KODU	FİYAT
13	20	60	6	2		50-10206P	1.034,00



## RULMANLI TEMİZLEME FREZE BİÇAKLARI

Laminat tezgahlarda hassas düzeltme çalışmaları yapmak, desenleri takip etmek ve karmaşık şekiller oluşturmak veya çoğaltmak için bu uçları kullanın.

### Makineler:

El tipi yönlendiriciler ve masa yönlendiriciler



### Malzeme:

Yumuşak ve sert ağaç, kontrplak ve ahşap paneller

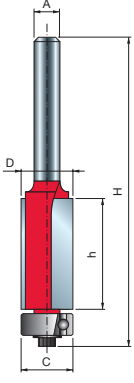

D mm	h mm	H mm	A mm	Z	AÇIKLAMA	ÜRÜN KODU	FİYAT
9.53	25.8	72.4	6	2		42-10006P	743,00
12.7	25.7	72.9	6	2		42-10406P	739,00
9.53	25.8	72.4	8	2		42-10008P	763,00
12.7	25.7	72.9	8	2		42-10408P	777,00
12.7	25.4	82.5	12	2		42-11012P	872,00
12.7	38.5	94.1	12	2		42-11412P	956,00
12.7	50.8	106.8	12	2		42-11612P	1.065,00

## RULMANLI / RULMANSIZ PAH FREZE BİÇAKLARI

Kenarları yumuşatan pah kırma uçları, herhangi bir iş parçasının kenarında düzgün bir pah oluşturur.

### Makineler:

El tipi yönlendiriciler, masa yönlendiriciler ve CNC makineleri. **Rulmanlı uçların CNC makinelerde kullanılması tavsiye edilmez.**

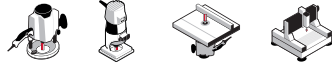

### Malzeme:

Yumuşak ve sert ağaç, kontrplak ve ahşap paneller

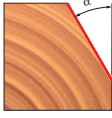
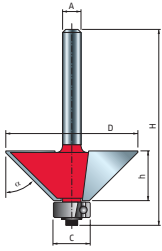

D mm	h mm	H mm	A mm	Z	C mm	α°	MAKSİMUM DEVİR	ÜRÜN KODU	FİYAT
25.4	25.1	67.25	6	2	12.7	15°	24.000	40-09806P	1.291,00
30.1	22.5	64.7	6	2	12.7	22.5°	18.000	40-10106P	1.326,00
31	9.5	52.3	6	2	12.7	45°	18.000	40-10506P	977,00
24	14	46	6	2		15°	24.000	40-90006P	1.117,00
24	12	44	6	2		30°	24.000	40-90206P	1.151,00
25	8	40.3	6	2		45°	24.000	40-90406P	1.081,00
25.4	25.1	73.25	12	2	12.7	15°	24.000	40-09812P	1.428,00
30.1	22.5	70.7	12	2	12.7	22.5°	18.000	40-10112P	1.428,00
44	18.5	67	12	2	12.7	45°	16.000	40-11412P	1.395,00

## RULMANLI LAMBA YERİ AÇMA FREZE BİÇAKLARI

Güçlü bindirmeli bağlantılar yapmak, dolapların arka panellerine girmek için girintiler kesmek veya gömme kalıpta ilginç bir ayrıntı oluşturmak için kullanın.

### Makineler:

El tipi yönlendiriciler ve masa yönlendiriciler



### Malzeme:

Yumuşak ve sert ağaç, kontrplak ve ahşap paneller

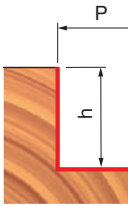
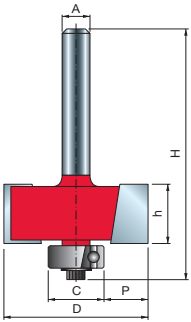
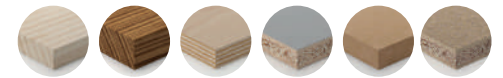

D mm	h mm	H mm	A mm	Z	C mm	P mm	MAKSİMUM DEVİR	ÜRÜN KODU	FİYAT
31.75	13.2	55.7	6	2	12.7	9.52	18.000	32-10006P	899,00
34.92	12.7	54.4	6	2	12.7	11.1	16.000	32-50006P	934,00
31.75	13.2	61.7	12	2	12.7	9.52	18.000	32-10212P	1.095,00
34.92	12.7	60.7	12	2	12.7	11.1	16.000	32-52012P	1.136,00

## RULMANLI BALIK SIRTI FREZE BIÇAKLARI

Herhangi bir iş parçasının keskin kenarlarını yumuşatır.

### Makinelere:

El tipi yönlendiriciler ve masa yönlendiriciler



### Malzeme:

Yumuşak ve sert ağaç, kontrplak ve ahşap paneller

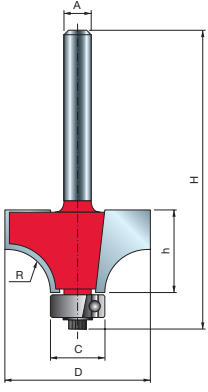

D mm	h mm	H mm	A mm	Z	C mm	R mm	MAKSİMUM DEVİR	ÜRÜN KODU	FİYAT
16.7	12.7	54.9	6	2	12.7	2	24.000	34-10106P	848,00
19.05	12.7	55.2	6	2	12.7	3.18	24.000	34-10406P	966,00
22.22	12.7	54.9	6	2	12.7	4.8	24.000	34-10806P	796,00
25.4	12.7	55.2	6	2	12.7	6.35	24.000	34-11006P	861,00
28.58	12.7	55.2	6	2	12.7	8	18.000	34-11206P	920,00
31.75	18	59.7	6	2	12.7	9.53	18.000	34-11406P	966,00
38.1	19.1	61.25	6	2	12.7	12.7	16.000	34-11606P	1.091,00
16.7	12.7	54.9	8	2	12.7	2	24.000	34-10108P	824,00
18.7	12.7	54.9	8	2	12.7	3	24.000	34-10308P	898,00
22.22	13.2	54.9	8	2	12.7	4.75	24.000	34-10808P	810,00
25.4	12.7	55.2	8	2	12.7	6.35	24.000	34-11008P	896,00
28.58	12.7	55.2	8	2	12.7	7.94	18.000	34-11208P	936,00
31.75	18	59.7	8	2	12.7	9.5	18.000	34-11408P	834,00
38.1	19.1	61.25	8	2	12.7	12.7	16.000	34-11608P	1.129,00
44.44	22.2	64.72	8	2	12.7	15.8	16.000	34-12708P	1.341,00
25.4	12.7	61.2	12	2	12.7	6.35	24.000	34-12012P	1.106,00
31.75	18	65.7	12	2	12.7	9.53	18.000	34-12412P	1.232,00
38.1	19.05	67.25	12	2	12.7	12.7	16.000	34-12612P	1.376,00
44.44	22.22	70.72	12	2	12.7	15.8	16.000	34-12712P	1.622,00
50.8	25.4	73.9	12	2	12.7	19	16.000	34-12812P	1.669,00
57.15	31.4	79.85	12	2	12.7	22.2	16.000	34-13012P	2.727,00
63.5	31.3	79.75	12	2	12.7	25.4	12.000	34-13212P	2.727,00
69.85	34.9	83.3	12	2	12.7	28.6	12.000	34-13412P	2.987,00
76.2	38.1	86.6	12	2	12.7	31.8	12.000	34-13612P	3.430,00

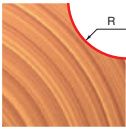
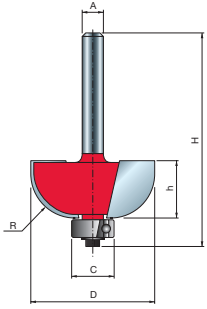

## RULMANLI TERS BALIK SIRTI FREZE BIÇAKLARI

Geleneksel mobilyalar için dekoratif içbükey kenar.

### Makinelere:

El tipi yönlendiriciler ve masa yönlendiriciler



### Malzeme:

Yumuşak ve sert ağaç, kontrplak ve ahşap paneller



D mm	h mm	H mm	A mm	Z	C mm	R mm	MAKSİMUM DEVİR	ÜRÜN KODU	FİYAT
25.4	12.7	54.7	6	2	9.53	8	24.000	30-10306P	1.027,00
31.75	12.7	55.2	6	2	12.7	9.53	18.000	30-10406P	1.027,00
38.1	16.4	58.9	6	2	12.7	12.7	16.000	30-10606P	1.077,00
19.05	14	62.4	12	2	9.53	4.75	24.000	30-10012P	1.081,00
22.23	12.7	60.7	12	2	9.53	6.35	24.000	30-11012P	1.001,00
25.4	12.7	60.7	12	2	9.53	8	24.000	30-11112P	1.192,00
31.75	12.7	61.2	12	2	12.7	9.5	18.000	30-11212P	1.227,00

## RULMANLI TAÇ MOTİF FREZE BİÇAĞI

Herhangi bir iş parçası üzerinde dekoratif kenar detayı.

### Makineler:

El tipi yönlendiriciler ve masa yönlendiriciler



### Malzeme:

Yumuşak ve sert ağaç, kontrplak ve ahşap paneller



D mm	h mm	H mm	A mm	Z	C mm	R1/R2 mm	MAKSİMUM DEVİR	ÜRÜN KODU	FİYAT
41.3	15.9	64.4	12	2	12.7	10/4.3	16.000	99-01112P	1.419,00

## RULMANLI ÇOKLU MOTİF FREZE BİÇAĞI

Yükseklik ve korkuluk ayarlarını değiştirerek ve çoklu geçişler yaparak sonsuz sayıda profil tasarımı üretin.

### Makineler:

Masa tipi yönlendiriciler



### Malzeme:

Yumuşak ve sert ağaç, kontrplak ve ahşap paneller



D mm	h mm	H mm	A mm	Z	C mm	R1/R2/R3	MAKSİMUM DEVİR	ÜRÜN KODU	FİYAT
23.8	35	83.5	12	2	12.7	3.5/4.5/8.5	24.000	99-01312P	1.767,00

## YARIMAY FREZE BİÇAKLARI

Herhangi bir iş parçasında tamamen yuvarlatılmış yarım daire biçimli bitiş oluşturur.

### Makineler:

El tipi yönlendiriciler, masa yönlendiriciler ve CNC makineleri

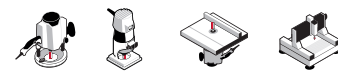

### Malzeme:

Yumuşak ve sert ağaç, kontrplak ve ahşap paneller



D mm	h mm	H mm	A mm	Z	R mm	MAKSİMUM DEVİR	ÜRÜN KODU	FİYAT
19	12.4	53.4	12	2	3.2	24.000	82-11012P	947,00
22.22	19.5	60.5	12	2	4.76	24.000	82-11212P	1.207,00
25.4	22.9	64.9	12	2	6.35	24.000	82-11412P	1.272,00
37	29.05	71.05	12	2	9.5	16.000	82-11612P	1.455,00
45.9	35.4	73.4	12	2	12.7	16.000	82-11812P	2.262,00

## KÜRE FREZE BİÇAKLARI

Yarım daire biçimli oyulmuş oluklar yapar.

### Makineler:

El tipi yönlendiriciler, masa yönlendiriciler ve CNC makineleri. **Rulmanlı uçların CNC makinelerde kullanılması tavsiye edilmez.**

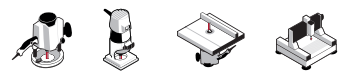

### Malzeme:

Yumuşak ve sert ağaç, kontrplak ve ahşap paneller



D mm	h mm	H mm	A mm	Z	R mm	MAKSİMUM DEVİR	ÜRÜN KODU	FİYAT
6	12.7	50.8	6	2	3	24.000	*18-10406P	942,00
6	9.5	57	12	2	3	24.000	*18-11412P	1.221,00
9.52	9	46	6	2	4.8	24.000	18-10606P	599,00
12	9	46	6	2	6	24.000	18-10806P	625,00
15.88	11	50.8	6	2	8	24.000	18-11006P	663,00
12.7	31.7	71.5	12	2	6.35	24.000	18-11612P	972,00
19.05	31.7	73	12	2	9.5	24.000	18-12212P	1.087,00
25.4	31.7	73	12	2	12.7	24.000	18-12612P	1.455,00

\* KARBÜR

## RULMANLI SOFT MOTİF FREZE BIÇAKLARI

Herhangi bir iş parçası üzerinde dekoratif kenar detayı.

## Makineler:

El tipi yönlendiriciler ve masa yönlendiriciler



## Malzeme:

Yumuşak ve sert ağaç, kontrplak ve ahşap paneller



D mm	h mm	H mm	A mm	Z	C mm	R mm	MAKSİMUM DEVİR	ÜRÜN KODU	FİYAT
31.75	12.2	53.9	6	2	9.53	4.8	18.000	38-20206P	1.043,00
38.1	16.2	57.4	6	2	9.53	6.35	16.000	38-20406P	1.301,00
31.75	12.2	53.9	8	2	9.53	4.8	18.000	38-20208P	1.086,00
38.1	16.2	57.4	8	2	9.53	6.35	16.000	38-20408P	1.355,00
31.75	12.2	59.9	12	2	9.53	4.8	18.000	38-21212P	1.305,00
38.1	16.2	63.4	12	2	9.53	6.35	16.000	38-21412P	1.477,00

D mm	h mm	H mm	A mm	Z	C mm	R mm	MAKSİMUM DEVİR	ÜRÜN KODU	FİYAT
27	13.3	61.31	12	2	9.53	4	18.000	38-10412P	1.120,00
35	18.5	66.5	12	2	9.53	6.35	16.000	38-10612P	1.269,00

D mm	h mm	H mm	A mm	Z	C mm	R1/R2 mm	MAKSİMUM DEVİR	ÜRÜN KODU	FİYAT
28.58	12.7	54.9	6	2	12.7	4/4	18.000	38-60206P	1.015,00
28.58	12.7	54.9	8	2	12.7	4/4	18.000	38-60208P	1.058,00
28.58	12.7	61.2	12	2	12.7	4/4	18.000	38-61212P	1.234,00
34.92	17.5	65.7	12	2	12.7	6.35/4.76	16.000	38-61412P	1.554,00

D mm	h mm	H mm	A mm	Z	C mm	R mm	MAKSİMUM DEVİR	ÜRÜN KODU	FİYAT
32.7	15	57.2	6	2	12.7	5	16.000	38-90006P	1.269,00

D mm	h mm	H mm	A mm	Z	C mm	R mm	MAKSİMUM DEVİR	ÜRÜN KODU	FİYAT
29.38	13.5	61.2	12	2	9.53	3.97	18.000	38-31212P	1.339,00
38.92	18.3	66	12	2	9.53	6.35	16.000	38-31412P	1.501,00

D mm	h mm	H mm	A mm	Z	C mm	R mm	MAKSİMUM DEVİR	ÜRÜN KODU	FİYAT
34.92	14.3	62.8	12	2	12.7	4.8	16.000	99-00512P	1.610,00

## KIRLANGIÇ FREZE BIÇAKLARI

Kırlangıç bağlantılar, çekmeceler, kutular ve açıkta kalan mobilya bağlantıları için güçlü, çekici bağlantılar için geleneksel seçimdir.

### Makineler:

El tipi yönlendiriciler, masa yönlendiriciler ve CNC makineleri

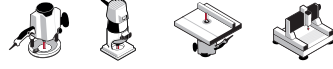

### Malzeme:

Yumuşak ve sert ağaç, kontrplak ve ahşap paneller

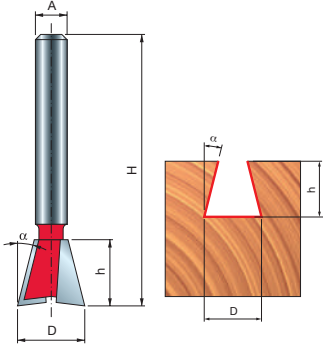

D mm	h mm	H mm	A mm	Z	a°	MAKSİMUM DEVİR	ÜRÜN KODU	FİYAT
12.7	12.7	59.7	12	2	14°	24.000	22-11212P	743,00
19.05	22.2	66.7	12	2	7°	24.000	22-11412P	917,00

## V KANAL FREZE BIÇAKLARI

V şeklindeki oluklar, tabela yapımı, gravür ve dekoratif detaylar için uygundur.

### Makineler:

El tipi yönlendiriciler, masa yönlendiriciler ve CNC makineleri



### Malzeme:

Yumuşak ve sert ağaç, kontrplak ve ahşap paneller

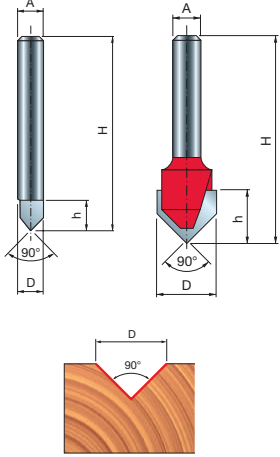

D mm	h mm	H mm	A mm	Z	a°	MAKSİMUM DEVİR	ÜRÜN KODU	FİYAT
6	6	38.1	6	1	90°	24.000	*20-10006P	692,00
12.7	10	44.4	6	2	90°	24.000	20-10406P	636,00
19.05	12.5	57.2	12	2	90°	24.000	20-10812P	853,00

\* Karbür

## PANEL BOŞALTMA FREZE BIÇAĞI

Panel ve diğer uygulamalarda açıklıkları kesmek ve kırmak için hızlı ve verimli bir çözümdür

### Makineler:

El tipi yönlendiriciler



### Malzeme:

Yumuşak ve sert ağaç, kontrplak ve ahşap paneller

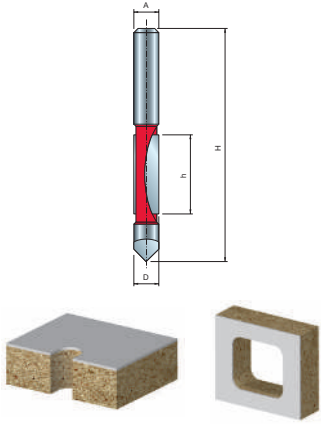

D mm	h mm	H mm	A mm	Z	MAKSİMUM DEVİR	ÜRÜN KODU	FİYAT
12.7	31.75	96.2	12	2	24.000	28-10412P	913,00

## 45° EKLEME FREZE BIÇAKLARI

Son derece güçlü birbirine kenetlenen bağlantılar oluşturur.

### Makineler:

Masa tipi yönlendiriciler ve CNC makinesi

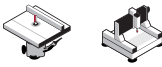

### Malzeme:

Yumuşak ve sert ağaç, kontrplak, ahşap kompozitler ve tüm katı yüzey malzemeleri

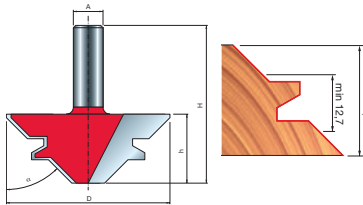

D mm	h mm	H mm	A mm	a°	Z	MAKSİMUM DEVİR	ÜRÜN KODU	FİYAT
55	23	61	12	45°	2	16.000	99-03512P	2.362,00
70	29.5	67.5	12	45°	2	12.000	99-03412P	3.310,00

## FINGER JOINT FREZE BIÇAĞI

Tamamen düz bir yüzey oluşturun ve daha güçlü bir bağlantı için yapıştırma alanını genişletin.

### Makineler:

Masa yönlendiriciler ve CNC makineleri



### Malzeme:

Yumuşak ve sert ağaç, kontrplak ve ahşap paneller



D mm	h mm	H mm	A mm	Z	a°	MAKSİMUM DEVİR	ÜRÜN KODU	FİYAT
35	41.5	79.5	12	2	14°	16.000	99-03712P	2.993,00

## TAS MENTEŞELER 57,5 MM

Menteşeler için uygun HW uçlu delme uçları

### Makineler:

CNC, delme ve çoklu delme makineleri



**Malzemeler:** Yumuşak ve sert ağaç, ahşap paneller ve MDF

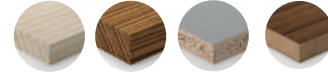

D mm	H mm	A mm	Z mm	AÇIKLAMA	SAĞ	FİYAT
15	57.5	10X25	2+2	ÇOKLU DELİK-CNC DELİK	PC04MD 153	824,00
20	57.5	10X25	2+2	ÇOKLU DELİK-CNC DELİK	PC04MD 203	923,00
22	57.5	10X25	2+2	ÇOKLU DELİK-CNC DELİK	PC04MD 223	1.008,00
25	57.5	10X25	2+2	ÇOKLU DELİK-CNC DELİK	PC04MD 253	976,00
26	57.5	10X25	2+2	ÇOKLU DELİK-CNC DELİK	PC04MD 263	1.038,00
35	57.5	10X25	2+2	ÇOKLU DELİK-CNC DELİK	PC04MD 353	1.019,00
40	57.5	10X25	2+2	ÇOKLU DELİK-CNC DELİK	PC04MD 403	1.486,00

Sağ

## TAS MENTEŞELER 70 MM

Menteşeler için uygun HW uçlu delme uçları

### Makineler:

CNC, delme ve çoklu delme makineleri



**Malzemeler:** Yumuşak ve sert ağaç, ahşap paneller ve MDF



D mm	H mm	A mm	Z mm	AÇIKLAMA	SAĞ	FİYAT
15	70	10X25	2+2	ÇOKLU DELİK-CNC DELİK	PC05MD 153	915,00
20	70	10X25	2+2	ÇOKLU DELİK-CNC DELİK	PC05MD 203	1.098,00
25	70	10X25	2+2	ÇOKLU DELİK-CNC DELİK	PC05MD 253	1.038,00
35	70	10X25	2+2	ÇOKLU DELİK-CNC DELİK	PC05MD 353	1.119,00
40	70	10X25	2+2	ÇOKLU DELİK-CNC DELİK	PC05MD 403	1.554,00

Sağ

## ALÜMİNYUM PANEL KATLAMA İÇİN V KANAL FREZE BİÇAKLARI

freud

Alüminyum panellerin kolay ve kırılmadan katlanması için V kanal açılması için tasarlanmıştır.

### Makineler:

El tipi yönlendiriciler, masa yönlendiriciler ve CNC makineleri

### Malzeme:

Alüminyum, Yumuşak ve sert ağaç, kontrplak ve ahşap paneller

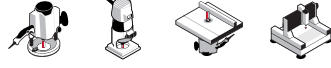
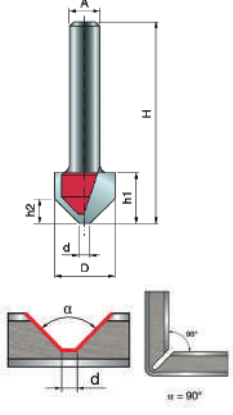

D mm	h1 mm	h2 mm	H mm	A mm	d mm	α°	Z	MAKSİMUM DEVİR	ÜRÜN KODU	FİYAT
16	12.5	6.8	50.8	6	2.5	90°	2	24.000	21-11206P	1.148,00
16	12.5	6.8	50.8	8	2.5	90°	2	24.000	21-11208P	1.186,00

## RULMANLI CORIAN FREZE BİÇAKLARI

freud

Pürüzsüz, yuvarlak bir kenar oluşturmak için masif yüzeyli tezgahlar ile masif yüzeyli lavabolar arasındaki bağlantıyı kesmek için tasarlanmıştır.

### Makineler:

El tipi yönlendiriciler ve masa yönlendiriciler

Malzeme: Yumuşak ve sert ağaç, kontrplak, ahşap kompozitler ve tüm katı yüzey malzemeleri

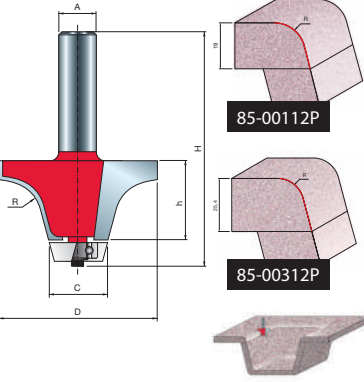

85-00112P

85-00312P



D mm	h mm	H mm	A mm	Z	C mm	R mm	MAKSİMUM DEVİR	ÜRÜN KODU	FİYAT
54	25.4	74.6	12	2	22.2	12.7	16.000	85-00112P	2.963,00
57.2	31.8	81	12	2	22.2	12.7	12.000	85-00312P	3.140,00

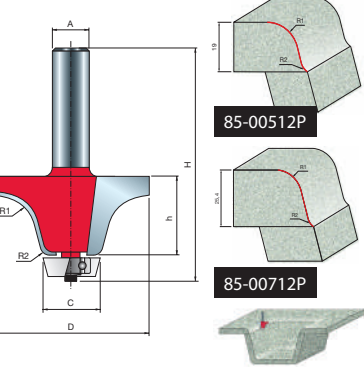

85-00512P

85-00712P

D mm	h mm	H mm	A mm	Z	C mm	R mm	MAKSİMUM DEVİR	ÜRÜN KODU	FİYAT
54	25.4	74.6	12	2	19.2	12.7/6.35	16.000	85-00512P	2.679,00
57.2	31.8	80.9	12	2	19.2	12.7/6.35	12.000	85-00712P	3.065,00

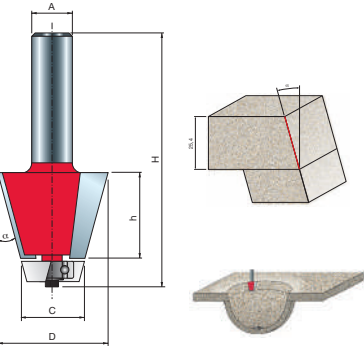

D mm	h mm	H mm	A mm	Z	C mm	α°	MAKSİMUM DEVİR	ÜRÜN KODU	FİYAT
35.6	25.4	78.1	12	2	22.2	15°	16.000	85-00912P	2.217,00

## KARBÜR FREZE KABA SİRALLİ Z=3 POZİTİF

freud

Çok yüksek ilerleme hızına sahip uygulamalar için talaş kırıcı CNC frezeleme.

### Özellikler:

Helisel yukarı kesim, iyi talaş akışı, yukarı doğru talaş tahliyesi



### Ne için uygun:

Ağaç kompozitleri ve masif ahşap malzemelerde kaba bir yüzey sağlayarak ebatlama, kanal açma ve dalma için

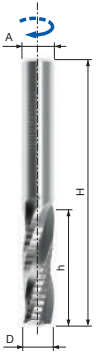

D mm	h mm	H mm	A mm	Z	AÇIKLAMA	ÜRÜN KODU	FİYAT
8	32	80	8	3	3 AĞIZLI KABA KESİM POZİTİF KARBÜR	SCH3URN506R	1.752,00
10	32	80	10	3	3 AĞIZLI KABA KESİM POZİTİF KARBÜR	SCH3URN512R	2.770,00
10	42	90	10	3	3 AĞIZLI KABA KESİM POZİTİF KARBÜR	SCH3URN514R	2.976,00
12	32	80	12	3	3 AĞIZLI KABA KESİM POZİTİF KARBÜR	SCH3URN518R	3.285,00
12	52	100	12	3	3 AĞIZLI KABA KESİM POZİTİF KARBÜR	SCH3URN522R	3.855,00
14	52	100	14	3	3 AĞIZLI KABA KESİM POZİTİF KARBÜR	SCH3URN530R	5.113,00
16	52	110	16	3	3 AĞIZLI KABA KESİM POZİTİF KARBÜR	SCH3URN536R	5.770,00
18	52	110	18	3	3 AĞIZLI KABA KESİM POZİTİF KARBÜR	SCH3URN540R	6.855,00
20	52	120	20	3	3 AĞIZLI KABA KESİM POZİTİF KARBÜR	SCH3URN546R	8.259,00
20	72	140	20	3	3 AĞIZLI KABA KESİM POZİTİF KARBÜR	SCH3URN548R	10.079,00

## KARBÜR FREZE FİNİŞ SİRALLİ Z=1 NEGATİF

freud

Yüksek talaş kaldırma oranı sağlayan geniş kanal boşluğuyla CNC frezeleme.

### Özellikler:

Helisel aşağı kesim, iş parçasını bağlamaya yardımcı olma, panelin üst tarafında en iyi yüzeyi sağlamak üzere, aşağı doğru talaş tahliyesi



### Ne için uygun:

Laminatlar, ağaç kompozitleri ve masif ahşap malzemelerde mükemmel bir yüzey sağlayarak ebatlama, kanal açma ve rampalı dalma için

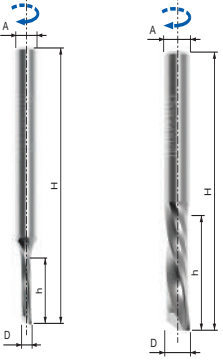

D mm	h mm	H mm	A mm	Z	AÇIKLAMA	ÜRÜN KODU	FİYAT
6	22	60	6	1	TEK AĞIZLI FİNİŞ KESİM NEGATİF KARBÜR	SCH1DFN225R	995,00
8	32	80	8	1	TEK AĞIZLI FİNİŞ KESİM NEGATİF KARBÜR	SCH1DFN240R	1.796,00

## KARBÜR FREZE FİNİŞ SİRALLİ Z=2 NEGATİF

freud

Mükemmel yüzeye sahip genel amaçlı CNC frezeleme.

### Özellikler:

Helisel aşağı kesim, iş parçasını bağlamaya yardımcı olma, panelin üst tarafında en iyi yüzeyi sağlamak üzere, aşağı doğru talaş tahliyesi



### Ne için uygun:

Laminatlar, ağaç kompozitleri ve masif ahşap malzemelerde mükemmel bir yüzey sağlayarak ebatlama, kanal açma ve rampalı dalma için

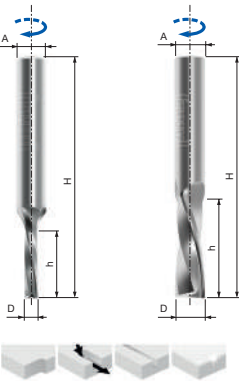

D mm	h mm	H mm	A mm	Z	AÇIKLAMA	ÜRÜN KODU	FİYAT
6	22	60	6	2	2 AĞIZLI FİNİŞ KESİM NEGATİF KARBÜR	SCH2DFN216R	995,00
8	32	80	8	2	2 AĞIZLI FİNİŞ KESİM NEGATİF KARBÜR	SCH2DFN228R	1.728,00

## KARBÜR FREZE FİNİŞ SİRALLİ Z=3 NEGATİF

freud

Yüksek ilerleme hızına sahip uygulamalar için CNC frezeleme.

### Özellikler:

Helisel aşağı kesim, iş parçasını bağlamaya yardımcı olma, panelin üst tarafında en iyi yüzeyi sağlamak üzere, aşağı doğru talaş tahliyesi



### Ne için uygun:

Laminatlar, ağaç kompozitleri ve masif ahşap malzemelerde mükemmel bir yüzey sağlayarak ebatlama, kanal açma ve rampalı dalma için

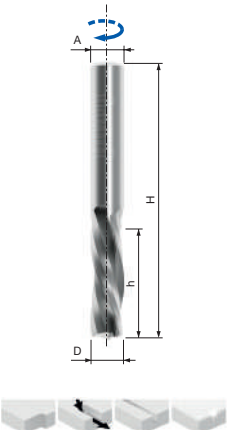

D mm	h mm	H mm	A mm	Z	AÇIKLAMA	ÜRÜN KODU	FİYAT
20	72	140	20	3	3 AĞIZLI FİNİŞ KESİM NEGATİF KARBÜR	SCH3DFN280R	9.452,00
20	92	170	20	3	3 AĞIZLI FİNİŞ KESİM NEGATİF KARBÜR	SCH3DFN284R	11.415,00



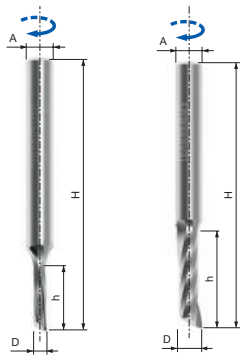

## KARBÜR FREZE FİNİŞ SİRALLI Z=1 POZİTİF

freud

Yüksek talaş kaldırma oranı sağlayan geniş kanal boşluğuyla CNC frezeleme.

### Özellikler:

Helisel yukarı kesim, iyi talaş akışı, panelin alt tarafında en iyi yüzeyi sağlamak üzere, yukarı doğru talaş tahliyesi



### Ne için uygun:

Laminatlar, ağaç kompozitleri ve masif ahşap malzemelerde mükemmel bir yüzey sağlayarak ebatlama, kanal açma ve dalma için



D mm	h mm	H mm	A mm	Z	AÇIKLAMA	ÜRÜN KODU	FİYAT
6	22	60	6	1	TEK AĞIZLI FİNİŞ KESİM POZİTİF KARBÜR	SCH1UFN225R	995,00
8	32	80	8	1	TEK AĞIZLI FİNİŞ KESİM POZİTİF KARBÜR	SCH1UFN240R	1.793,00

## KARBÜR FREZE FİNİŞ SİRALLI Z=2 POZİTİF

freud

Mükemmel yüzeye sahip genel amaçlı CNC frezeleme.

### Özellikler:

Helisel yukarı kesim, iyi talaş akışı, panelin alt tarafında en iyi yüzeyi sağlamak üzere, yukarı doğru talaş tahliyesi



### Ne için uygun:

Laminatlar, ağaç kompozitleri ve masif ahşap malzemelerde mükemmel bir yüzey sağlayarak ebatlama, kanal açma ve dalma için



D mm	h mm	H mm	A mm	Z	AÇIKLAMA	ÜRÜN KODU	FİYAT
6	22	60	6	2	2 AĞIZLI FİNİŞ KESİM POZİTİF KARBÜR	SCH2UFN216R	995,00
8	32	80	8	2	2 AĞIZLI FİNİŞ KESİM POZİTİF KARBÜR	SCH2UFN228R	1.752,00
10	32	80	10	2	2 AĞIZLI FİNİŞ KESİM POZİTİF KARBÜR	SCH2UFN240R	2.037,00
12	42	90	12	2	2 AĞIZLI FİNİŞ KESİM POZİTİF KARBÜR	SCH2UFN260R	2.631,00
16	52	100	16	2	2 AĞIZLI FİNİŞ KESİM POZİTİF KARBÜR	SCH2UFN280R	4.287,00
18	52	110	18	2	2 AĞIZLI FİNİŞ KESİM POZİTİF KARBÜR	SCH2UFN284R	5.346,00
20	52	120	20	2	2 AĞIZLI FİNİŞ KESİM POZİTİF KARBÜR	SCH2UFN288R	6.477,00

## KARBÜR FREZE FİNİŞ SİRALLI PERFORMANS Z=2+2 POZİTİF+NEGATİF

freud

Yüksek ilerleme hızına sahip uygulamalar için CNC frezeleme.

### Özellikler:

Helisel aşağı kesim, iş parçasını bağlamaya yardımcı olma, panelin üst tarafında en iyi yüzeyi sağlamak üzere, aşağı doğru talaş tahliyesi



### Ne için uygun:

Laminatlar, ağaç kompozitleri ve masif ahşap malzemelerde mükemmel bir yüzey sağlayarak ebatlama, kanal açma ve rampalı dalma için



D mm	h mm	H mm	A mm	Z	AÇIKLAMA	ÜRÜN KODU	FİYAT
6	22	70	6	2+2	PERFORMANS KESİM 2+2 POZİTİF-NEGATİF KARBÜR	RCL4M03001	1.737,00
8	22	70	8	2+2	PERFORMANS KESİM 2+2 POZİTİF-NEGATİF KARBÜR	SCH2XFN310R	1.796,00
8	32	70	8	2+2	PERFORMANS KESİM 2+2 POZİTİF-NEGATİF KARBÜR	SCH2XFN410R	1.930,00
10	32	80	10	2+2	PERFORMANS KESİM 2+2 POZİTİF-NEGATİF KARBÜR	SCH2XFN350R	2.372,00
12	32	90	12	2+2	PERFORMANS KESİM 2+2 POZİTİF-NEGATİF KARBÜR	SCH2XFN360R	2.775,00
12	42	100	12	2+2	PERFORMANS KESİM 2+2 POZİTİF-NEGATİF KARBÜR	SCH2XFN370R	3.542,00
18	55	110	18	2+2	PERFORMANS KESİM 2+2 POZİTİF-NEGATİF KARBÜR	SCH2XFN450R	7.507,00
20	55	120	20	2+2	PERFORMANS KESİM 2+2 POZİTİF-NEGATİF KARBÜR	SCH2XFN455R	8.009,00

## KARBÜR FREZE FİNİŞ SİRALLI PERFORMANS Z=3+3 POZİTİF+NEGATİF

freud

Panelin iki tarafında mükemmel yüzeye sahip, yüksek hız gerektiren uygulamalar için CNC frezeler

### Özellikler:

Panelin iki tarafında birden en iyi yüzeyi sağlamak üzere yukarı ve aşağı helis



### Ne için uygun:

Laminatlar, ağaç kompozitleri ve masif ahşap malzemelerde mükemmel bir yüzey sağlayarak ebatlama, kanal açma ve rampalı dalma için



D mm	h mm	H mm	A mm	Z	AÇIKLAMA	ÜRÜN KODU	FİYAT
8	32	70	8	3+3	PERFORMANS KESİM 3+3 POZİTİF-NEGATİF KARBÜR	SCH3XFN410R	2.184,00
10	29	80	10	3+3	PERFORMANS KESİM 3+3 POZİTİF-NEGATİF KARBÜR	SCH3XFN420R	2.775,00
12	42	100	12	3+3	PERFORMANS KESİM 3+3 POZİTİF-NEGATİF KARBÜR	SCH3XFN430R	3.197,00
12	52	100	12	3+3	PERFORMANS KESİM 3+3 POZİTİF-NEGATİF KARBÜR	SCH3XFN432R	3.766,00

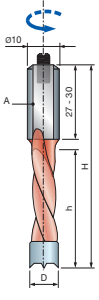

Sol

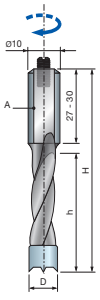

Sağ

## YARIM DELİK MATKAP UÇLARI 57,5 MM

Kör delikler için merkez noktalı HW uçlu dübel matkapları.

### Makinelere:

CNC, delme ve çoklu delme makineleri



**Malzemeler:** Yumuşak ve sert ağaç, ahşap paneller ve MDF



D mm	h mm	H mm	A mm	Z	AÇIKLAMA	SOL	SAĞ	FİYAT
4	27	57.5	10x27	2	ÇOKLU DELİK-CNC DELİK	PF06MS ZA3	PF06MD ZA3	515,00
5	27	57.5	10x27	2	ÇOKLU DELİK-CNC DELİK	PF06MS AA3	PF06MD AA3	411,00
6	27	57.5	10x27	2	ÇOKLU DELİK-CNC DELİK	PF06MS BA3	PF06MD BA3	482,00
8	27	57.5	10x27	2	ÇOKLU DELİK-CNC DELİK	PF06MS DA3	PF06MD DA3	451,00
9	27	57.5	10x27	2	ÇOKLU DELİK-CNC DELİK	PF06MS EA3	PF06MD EA3	604,00
10	27	57.5	10x27	2	ÇOKLU DELİK-CNC DELİK	PF06MS FA3	PF06MD FA3	590,00

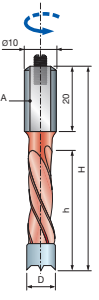

Sol

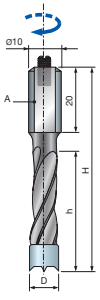

Sağ

## YARIM DELİK MATKAP UÇLARI 57,5 MM (ÇİFT TALAŞ)

### Makinelere:

CNC, delme ve çoklu delme makineleri



**Malzemeler:** Yumuşak ve sert ağaç, ahşap paneller ve MDF



D mm	h mm	H mm	A mm	Z	AÇIKLAMA	SOL	SAĞ	FİYAT
4	27	57.5	10x20	2	ÇOKLU DELİK-CNC DELİK	PF07MS ZA3	PF07MD ZA3	525,00
5	30	57.5	10x20	2	ÇOKLU DELİK-CNC DELİK	PF07MS AA3	PF07MD AA3	411,00
8	30	57.5	10x20	2	ÇOKLU DELİK-CNC DELİK	PF07MS DA3	PF07MD DA3	451,00
10	30	57.5	10x20	2	ÇOKLU DELİK-CNC DELİK	PF07MS FA3	PF07MD FA3	590,00

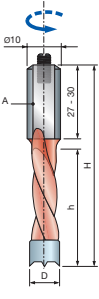

Sol

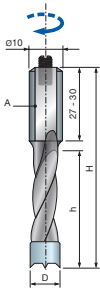

Sağ

## YARIM DELİK MATKAP UÇLARI 70 MM

### Makinelere:

CNC, delme ve çoklu delme makineleri



**Malzemeler:** Yumuşak ve sert ağaç, ahşap paneller ve MDF



D mm	h mm	H mm	A mm	Z	AÇIKLAMA	SOL	SAĞ	FİYAT
3	22	70	10x33	2	ÇOKLU DELİK-CNC DELİK	*PF26MS VC3	*PF26MD VC3	692,00
4	27	70	10x30	2	ÇOKLU DELİK-CNC DELİK	*PF26MS ZC3	*PF26MD ZC3	713,00
5	35	70	10x30	2	ÇOKLU DELİK-CNC DELİK	PF06MS AC3	PF06MD AC3	465,00
6	35	70	10x30	2	ÇOKLU DELİK-CNC DELİK	PF06MS BC3	PF06MD BC3	523,00
7	35	70	10x30	2	ÇOKLU DELİK-CNC DELİK	PF06MS CC3	PF06MD CC3	548,00
8	35	70	10x30	2	ÇOKLU DELİK-CNC DELİK	PF06MS DC3	PF06MD DC3	465,00
9	35	70	10x30	2	ÇOKLU DELİK-CNC DELİK	PF06MS EC3	PF06MD EC3	590,00
10	35	70	10x30	2	ÇOKLU DELİK-CNC DELİK	PF06MS FC3	PF06MD FC3	590,00
12	35	70	10x30	2	ÇOKLU DELİK-CNC DELİK	PF06MS GC3	PF06MD GC3	651,00

\* Karbür

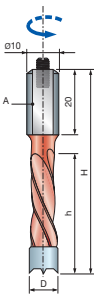

Sol

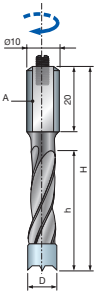

Sağ

## YARIM DELİK MATKAP UÇLARI 70 MM (ÇİFT TALAŞ)

### Makinelere:

CNC, delme ve çoklu delme makineleri



**Malzemeler:** Yumuşak ve sert ağaç, ahşap paneller ve MDF



D mm	h mm	H mm	A mm	Z	AÇIKLAMA	SOL	SAĞ	FİYAT
5	43	70	10x20	2	ÇOKLU DELİK-CNC DELİK	PF07MS AC3	PF07MD AC3	465,00
8	43	70	10x20	2	ÇOKLU DELİK-CNC DELİK	PF07MS DC3	PF07MD DC3	465,00
10	43	70	10x20	2	ÇOKLU DELİK-CNC DELİK	PF07MS FC3	PF07MD FC3	590,00

## TAM DELİK MATKAP UÇLARI 57,5 MM

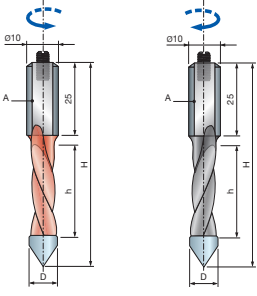

Sol

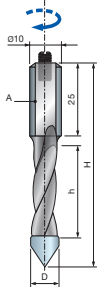

Sağ

## Makineler:

CNC, delme ve çoklu delme makineleri



Malzemeler: Yumuşak ve sert ağaç, ahşap paneller ve MDF



D mm	h mm	H mm	A mm	Z	AÇIKLAMA	SOL	SAĞ	FİYAT
4	22	57.5	10x25	2	ÇOKLU DELİK-CNC DELİK	PF10MS ZA3	PF10MD ZA3	590,00
5	22	57.5	10x25	2	ÇOKLU DELİK-CNC DELİK	PF10MS AA3	PF10MD AA3	590,00
6	22	57.5	10x25	2	ÇOKLU DELİK-CNC DELİK	PF10MS BA3	PF10MD BA3	590,00
7	22	57.5	10x25	2	ÇOKLU DELİK-CNC DELİK	PF10MS CA3	PF10MD CA3	628,00
8	22	57.5	10x25	2	ÇOKLU DELİK-CNC DELİK	PF10MS DA3	PF10MD DA3	628,00
10	22	57.5	10x25	2	ÇOKLU DELİK-CNC DELİK	PF10MS EA3	PF10MD EA3	651,00

## TAM DELİK MATKAP UÇLARI 70 MM

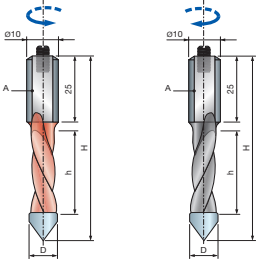

Sol

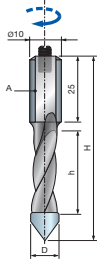

Sağ

## Makineler:

CNC, delme ve çoklu delme makineleri



Malzemeler: Yumuşak ve sert ağaç, ahşap paneller ve MDF



D mm	h mm	H mm	A mm	Z	AÇIKLAMA	SOL	SAĞ	FİYAT
3	20	70	10x40	2	ÇOKLU DELİK-CNC DELİK	*PF33MS VC3	*PF33MD VC3	689,00
4	27	70	10x30	2	ÇOKLU DELİK-CNC DELİK	*PF33MS ZC3	*PF33MD ZC3	688,00
5	35	70	10x25	2	ÇOKLU DELİK-CNC DELİK	PF10MS AC3	PF10MD AC3	493,00
6	35	70	10x25	2	ÇOKLU DELİK-CNC DELİK	PF10MS BC3	PF10MD BC3	641,00
7	35	70	10x25	2	ÇOKLU DELİK-CNC DELİK	PF10MS CC3	PF10MD CC3	682,00
8	35	70	10x25	2	ÇOKLU DELİK-CNC DELİK	PF10MS DC3	PF10MD DC3	572,00
10	35	70	10x25	2	ÇOKLU DELİK-CNC DELİK	PF10MS EC3	PF10MD EC3	725,00
12	35	70	10x25	2	ÇOKLU DELİK-CNC DELİK	PF10MS GC3	PF10MD GC3	870,00

\* KARBÜR

## TAM DELİK MATKAP UÇLARI 70 MM (ÇİFT TALAŞ)

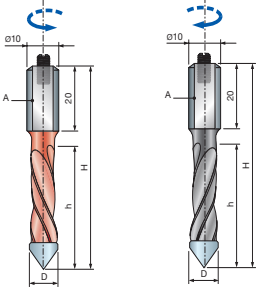

Sol

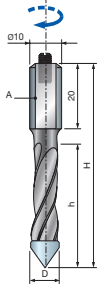

Sağ

## Makineler:

CNC, delme ve çoklu delme makineleri



Malzemeler: Yumuşak ve sert ağaç, ahşap paneller ve MDF



D mm	h mm	H mm	A mm	Z	AÇIKLAMA	SOL	SAĞ	FİYAT
5	40	70	10x20	2	ÇOKLU DELİK-CNC DELİK	PF11MS AC3	PF11MD AC3	493,00
8	40	70	10x20	2	ÇOKLU DELİK-CNC DELİK	PF11MS DC3	PF11MD DC3	572,00
10	40	70	10x20	2	ÇOKLU DELİK-CNC DELİK	PF11MS FC3	PF11MD FC3	725,00

## TAS MENTEŞELER 57,5 MM

**Makinelere:**  
CNC, delme ve çoklu delme makineleri



**Malzemeler:** Yumuşak ve sert ağaç, ahşap paneller ve MDF

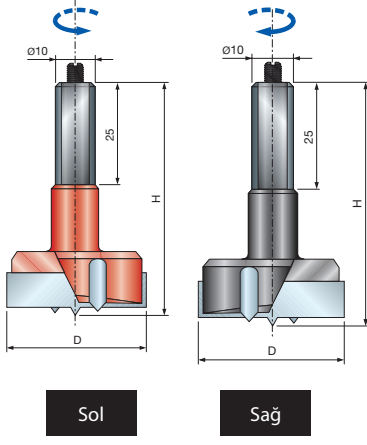
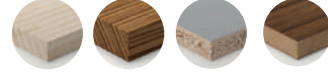

D mm	H mm	A mm	Z mm	AÇIKLAMA	SOL	SAĞ	FİYAT
15	57.5	10X25	2+2	ÇOKLU DELİK-CNC DELİK	PC04MS 153	PC04MD 153	824,00
20	57.5	10X25	2+2	ÇOKLU DELİK-CNC DELİK	PC04MS 203	PC04MD 203	923,00
22	57.5	10X25	2+2	ÇOKLU DELİK-CNC DELİK	PC04MS 223	PC04MD 223	1.008,00
25	57.5	10X25	2+2	ÇOKLU DELİK-CNC DELİK	PC04MS 253	PC04MD 253	976,00
26	57.5	10X25	2+2	ÇOKLU DELİK-CNC DELİK	PC04MS 263	PC04MD 263	1.038,00
35	57.5	10X25	2+2	ÇOKLU DELİK-CNC DELİK	PC04MS 353	PC04MD 353	1.019,00
40	57.5	10X25	2+2	ÇOKLU DELİK-CNC DELİK	PC04MS 403	PC04MD 403	1.486,00

## TAS MENTEŞELER 70 MM

**Makinelere:**  
CNC, delme ve çoklu delme makineleri



**Malzemeler:** Yumuşak ve sert ağaç, ahşap paneller ve MDF

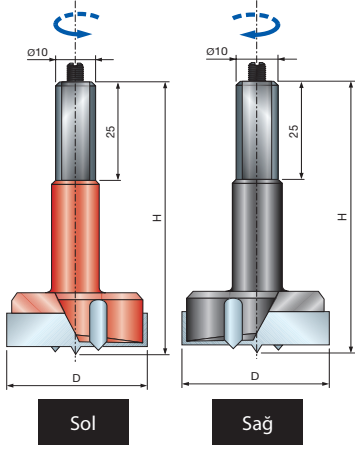

D mm	H mm	A mm	Z mm	AÇIKLAMA	SOL	SAĞ	FİYAT
15	70	10X25	2+2	ÇOKLU DELİK-CNC DELİK	PC05MS 153	PC05MD 153	915,00
20	70	10X25	2+2	ÇOKLU DELİK-CNC DELİK	PC05MS 203	PC05MD 203	1.098,00
25	70	10X25	2+2	ÇOKLU DELİK-CNC DELİK	PC05MS 253	PC05MD 253	1.038,00
35	70	10X25	2+2	ÇOKLU DELİK-CNC DELİK	PC05MS 353	PC05MD 353	1.119,00
40	70	10X25	2+2	ÇOKLU DELİK-CNC DELİK	PC05MS 403	PC05MD 403	1.554,00

## HAVŞALAR

Yan sabitleme vidalı HW uçlu havşa kesiciler

**Makinelere:**  
CNC, delme ve çoklu delme makineleri



**Malzemeler:** Yumuşak ve sert ağaç, ahşap paneller ve MDF

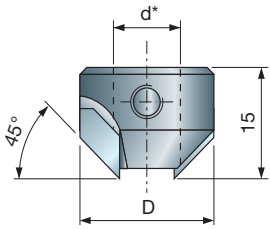

D mm	d mm	H mm	Z mm	AÇIKLAMA	SOL	SAĞ	FİYAT
16	5	15	2		SV05MS AA3	SV05MD AA3	680,00
18	8	15	2		SV05MS DA3	SV05MD DA3	690,00
20	10	15	2		SV05MS FA3	SV05MD FA3	700,00



## IZAR ALUMİNYUM / PVC TEK FREZE UÇLARI HSS-E

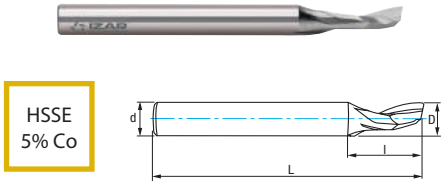

HSSE  
5% Co

D mm	l mm	L mm	d mm	ÜRÜN KODU	FİYAT
3	12	60	8	83500	455,00
4	12	60	8	83499	460,00
5	12	60	8	82297	465,00
6	14	60	8	83498	470,00

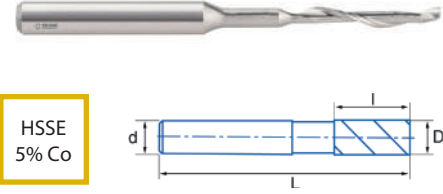

HSSE  
5% Co

## IZAR ALUMİNYUM / PVC TEK FREZE UÇLARI HSS-E



D mm	l mm	Y mm	L mm	d mm	ÜRÜN KODU	FİYAT
4	16	29	90	8	83497	650,00
5	16	29	90	8	83496	780,00
5	18	17	80	8	81500	553,00
5	25	30	100	8	83495	825,00
5	25	50	120	8	83494	855,00
10	30	40	100	10	83493	1.000,00

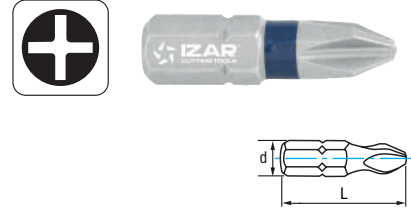

## IZAR BITS UÇ PH



D mm	L mm	d mm	AÇIKLAMA	ÜRÜN KODU	FİYAT	
2	25	6.35	5'Lİ PAKET	33139	24,00	
*	2	25	6.35	5'Lİ PAKET	33174	30,00
2	50	6.35	5'Lİ PAKET	22654	39,00	
*	2	50	6.35	5'Lİ PAKET	26551	52,00
2	75	6.35	5'Lİ PAKET	23271	61,00	
2	100	6.35	5'Lİ PAKET	23275	78,00	

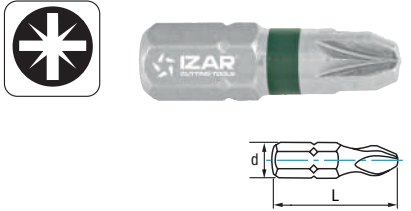

## IZAR BITS UÇ PZ



D mm	L mm	d mm	AÇIKLAMA	ÜRÜN KODU	FİYAT
2	25	6.35	5'Lİ PAKET	33142	24,00
2	50	6.35	5'Lİ PAKET	22663	39,00
2	75	6.35	5'Lİ PAKET	23291	61,00
2	100	6.35	5'Lİ PAKET	23293	78,00



## IZAR BITS UÇ TORK



D mm	L mm	d mm	AÇIKLAMA	ÜRÜN KODU	FİYAT
25	50	6.35	5'Lİ PAKET	22676	39,00
30	50	6.35	5'Lİ PAKET	22678	44,00
30	75	6.35	5'Lİ PAKET	23398	78,00
30	100	6.35	5'Lİ PAKET	23400	96,00

## IZAR STOPERLİ BITS UÇ PZ



D mm	L mm	d mm	AÇIKLAMA	ÜRÜN KODU	FİYAT
2	25	6.35	2'Lİ PAKET	81588	74,00



## IZAR BİTS UÇ ADAPTÖRÜ MANYETİK



L mm	d mm	AÇIKLAMA	ÜRÜN KODU	FİYAT
60	6.35	TEKLİ PAKET	33747	130,00



## IZAR BİTS UÇ ADAPTÖRÜ MANYETİK KİLİTLİ (BAS-AÇ)



L mm	d mm	AÇIKLAMA	ÜRÜN KODU	FİYAT
60	6.35	TEKLİ PAKET	82687	302,00

## IZAR 13 PARÇA BİTS UÇ SETİ



AÇIKLAMA	ÜRÜN KODU	FİYAT
PH 1 2 3 25mm	83770	515,00
PZ 1 2 3 25mm		
TX 10 15 20 25 30 40 25mm		
Bits uç adaptörü Manyetik Kilitli (Bas Aç)		

\* 1 paket, 12 adet yukarıda içeriği belirtilen 13 parça setten oluşur.



## IZAR 31 PARÇA BİTS UÇ SETİ



AÇIKLAMA	ÜRÜN KODU	FİYAT
PH 1 25mm 2 adet	68168	777,00
2 25mm 3 adet		
3 25mm 1 adet		
PZ 1 25mm 2 adet		
2 25mm 8 adet		
3 25mm 2 adet		
TX 10 25mm 1 adet		
15 25mm 2 adet		
20 25mm 2 adet		
25 25mm 3 adet		
30 25mm 3 adet		
40 25mm 1 adet		

Bits uç adaptörü Manyetik Kilitli (Bas Aç)

\* 1 paket, 6 adet yukarıda içeriği belirtilen 31 parça setten oluşur.



**Everest İnş Malz. Ür. Ve Paz. A.Ş**

İmes 501. Sk. No 13 Y.Dudullu  
34760 İstanbul  
Tel. (216) 311 16 70  
Fax. (216) 311 16 74  
info@everestas.com  
www.everestas.com

